



Actuator SQM40/SQM41

## Actuators for air and gas dampers

**SQM40...**  
**SQM41...**

- Electromotoric actuator up to 18 Nm torque
- Clockwise and counterclockwise variants
- Running times from 5 to 65 seconds
- Different shaft ends available
- Electronic version with analog control input
- Internal position indication
- Drive shaft can be disengaged
- Variants with UL and CSA approval, as well as GL marine approval

The SQM40/SQM41 and this Data Sheet are intended for use by OEMs which integrate the actuators in their products!

### Use

The SQM40/SQM41 actuators are suited for driving oil pressure controller, butterfly valves, dampers or for use on other applications that require rotary motion. Areas of application are oil and gas burners of medium to higher capacity as well as thermal process plants.

The actuators are used primarily for load-dependent control of the flow of gas, oil and combustion air:

- In connection with modulating 3-position controllers or continuous controllers (e.g., 4...20 mA) and/or...
- ... directly by burner controls

## Supplementary documentation

Product type	Type of documentation	Documentation number
SQM45 / SQM48	Data Sheet	N7814
SQM10 / SQM20	Data Sheet	N7812
ASZ	Data Sheet	N7921

## Warning notes



**To avoid injury to persons, damage to property or the environment, the following warning notes must be observed!**

**Only qualified personnel may open, interfere with or modify the actuators!**

- Read the documentation on the actuators carefully and fully. If not observed, dangerous situations might occur
- The user must ensure that the actuators meet the requirements of the relevant application standards
- Safety-related applications are only available with Siemens burner controls!
- All product-related activities (mounting, settings and maintenance) must be performed by qualified and authorized personnel



### Caution!

- Risk of electric shock hazard – to disconnect the actuator from power, it may be necessary to open more than one switch. Before performing maintenance work, the actuator must be disconnected from power
  - The electrical connection between the conduit fittings is not made automatically. It must be established on installation site
  - The connecting plate is made of plastic and does not provide earthing of the conduit fittings. Earthing must be ensured by adequate washers and wire links
  - All cam switch settings must satisfy the requirements of the relevant application standards
- 
- To provide protection against electric shock hazard, the connecting terminals must have adequate touch protection. Make certain that non-insulated connections or wires cannot be touched
  - Each time work has been carried out (mounting, installation, service work, etc.), check to ensure that wiring is in an orderly state
  - Fall or shock can adversely affect the safety functions. Such actuators must not be put into operation even if they do not exhibit any damage
  - Static charges must be avoided since they can damage the actuator's electronic components when touched.
- Recommendation:** Use ESD equipment

## Notes on use in North America

- Use of flexible conduit including adequate accessories is mandatory
- Use of copper wiring is mandatory
- All circuits of class 2 must use cables type CL3, CL3R, CL3P or comparable types, OR  
All circuits are wired according to class 1 (electrical light or power circuits)

## Mounting notes

---

- Ensure that the relevant national safety regulations and notes on standards are complied with
- In geographical areas where DIN regulations apply, the mounting and installation requirements of VDE must be satisfied, especially DIN/VDE 0100, 0550 and DIN/VDE 0722
- Make certain that the actuator is not exposed to direct solar radiation
- Required tightening torques for the fixing screws of the
  - housing cover: 3.5 Nm
  - connecting cover: 2 Nm
- To ensure degree of protection IP66, the user must fit suitable glands or plugs on the connector cover on the actuator. To ensure degree of protection IP66 throughout the lifetime of the actuator, the bearing of the actuator drive shaft must be located somewhere it will not be directly exposed to water or dust

## Installation notes

---

- Ensure that the electrical wiring is in compliance with national and local safety regulation
- Make certain that strain relief of the connected cables conforms to the relevant standards (e.g. as per DIN EN 60730 and DIN EN 60335)
- Ensure that spliced wires cannot get into contact with neighboring terminals. Use adequate ferrules
- Unused terminals of the SQM40/SQM41 must be covered by dummy plugs
- When making the wiring, the AC 120 V or AC 230 V section must be separated from other voltage sections, thus ensuring protection against electric shock hazard
- The connection between the actuator drive shaft and the relevant controlling element must be form-fitted
- Only plastic versions of cable glands may be used

## Electrical connection

---

- The actuators must always be powered via a prefuse of max. 6.3 AT (as per DIN EN 6012- 2/5)
- For the protective earth connection, the housing of all variants has a marked **PE** connecting terminal. A tightening torque of 1.2 Nm must be observed for fitting the screw
- The supplied RAST3.5 connectors or RAST5 connectors must be used with screw terminals for electrical connections. A tightening torque of 0.25 Nm must be observed for fitting the screw



### Note!

The connection of fuel valves is only permitted on fused output terminals, see chapter *Connection diagrams*. For this purpose, specific unit variants are available fitted with a unit-internal, non-replaceable fuse. The unit-internal fuse is used to protect each switching contact from welding in the event of external short-circuit. In addition, please note that the maximum current load for the fused output terminals is reduced, see chapter *Connection diagrams*.



### Note!

SELV or PELV depends on the safety class of the connected components. In the case of PELV, the relevant component is connected to protective earth.

## Cam settings

---

The mechanical setting facility for the cams is physically separated from the connection terminals. When the actuator is disconnected from power, the switches can be adjusted via a scale. The cams can be changed via adjusting screws. The scale indicates the angles of the switching points.

## Standards and certificates

---



### Applied directives:

- Low-voltage directive 2014/35/EC
- Electromagnetic compatibility EMC (immunity) 2014/30/EC

Compliance with the regulations of the applied directives is verified by the adherence to the following standards / regulations:

- Automatic electrical controls for household and similar use Part 2-14: Special requirements on electric actuators DIN EN 60730-2-14
- Automatic electrical controls for household and similar use Part 1: General requirements DIN EN 60730-1

**The relevant valid edition of the standards can be found in the declaration of conformity!**



EAC Conformity mark (Eurasian Conformity mark)



China RoHS

Hazardous substances table:

<http://www.siemens.com/download?A6V10883536>



For types marked with **R**

Example: SQM40.264**R**10

For use in US/Canada where the power supply lines require a connection facility for flexible conduit, the actuator's product no. includes type suffix «R» (see following example). These products are **UL** and **CSA** listed.



For types marked with **36** or **38**

Examples: SQM4x.36x**A**2x, SQM4x.38x**A**2x

**For marine applications, environmental category A.**

## Lifetime

---

The actuator has a designed lifetime\* of 250,000 start cycles (close ⇒ open ⇒ close) under load with the rated torque in the entire rotation angle range, which under normal operating conditions in heating mode corresponds to approx. 10 years of usage (starting from the date of manufacture on the device type plate). This lifetime is based on the endurance tests specified in standard EN 298. A summary of the conditions has been published by the European Control Manufacturers Association (Afecon - [www.afecor.org](http://www.afecor.org)).

The designed lifetime is based on use of the actuator according to the manufacturer's Data Sheet. After reaching the designed lifetime in terms of the number of startup cycles, or the respective time of usage time, the actuator is to be replaced by authorized personnel.

\* The designed lifetime is not the warranty time specified in the Terms of Delivery.

## Disposal notes

---

The SQM40/SQM41 contains electrical and electronic components and must not be disposed of together with domestic waste. Local and currently valid legislation must be observed.

## Mechanical design

- |             |   |
|-------------|---|
| Housing     | <ul style="list-style-type: none"> <li>• Lower housing part made of die-cast aluminum</li> <li>• Housing cover made of impact-proof and heat-resistant plastic</li> </ul>   |
| Drive motor | <ul style="list-style-type: none"> <li>• Synchronous motor</li> </ul>   |
| Coupling    | <ul style="list-style-type: none"> <li>• Shaft can be manually disengaged from the motor by operating the coupling (coupling pin (K1))</li> <li>• Automatic reengagement</li> </ul> <p>Disengagement of drive shaft / motor by pressing coupling pin «K1»</p> |

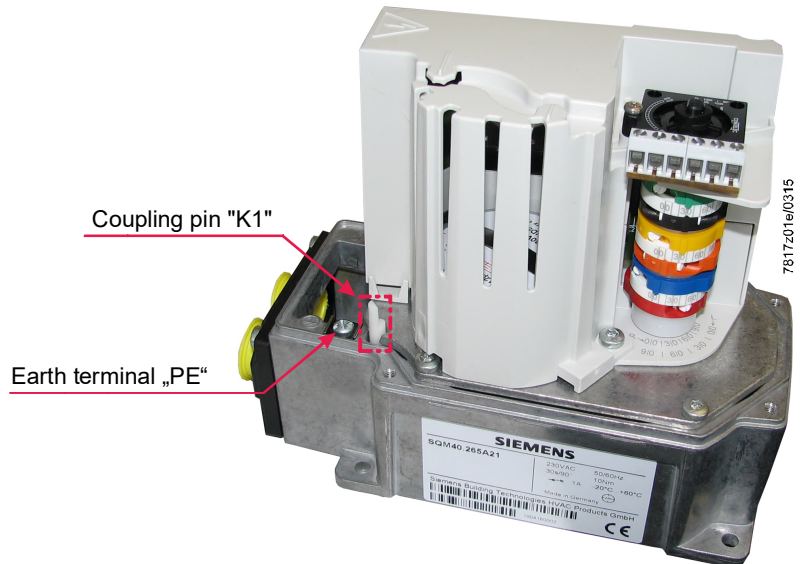

- |                                |   |
|--------------------------------|---|
| Earthing connection            | <ul style="list-style-type: none"> <li>• Earth terminal (PE) with screw fitting</li> </ul>  |
| Cam shaft drive                | <ul style="list-style-type: none"> <li>• Non-reactive gear</li> </ul>   |
| Adjustment of switching points | <ul style="list-style-type: none"> <li>• With adjustable cams</li> <li>• Scales beside the cams indicate the angle of the switching point</li> </ul>  |
| Position indicator             | <ul style="list-style-type: none"> <li>• Internally <ul style="list-style-type: none"> <li>– Scale 0...135° at the end of the cam assembly</li> <li>– Scale range to direction of rotation with arrow marking for SQM41 or with marking in slot die for SQM40</li> </ul> </li> </ul>  |
| Electrical connections         | <ul style="list-style-type: none"> <li>• RAST3.5 screw terminals are factory supplied, depending on the PCB variant</li> <li>• RAST5 screw terminals are factory supplied, depending on the PCB variant</li> <li>• Optional: Insulation displacement connectors</li> <li>• Cable entry by means of 2 openings in the connector cover supplied. The cable glands are not included in the scope of delivery</li> <li>• Large openings in the housing allow easy cable installation</li> </ul> |
| Gear train                     | Maintenance-free gearwheels and bearings.   |
| Drive shaft                    | <ul style="list-style-type: none"> <li>• Different shaft versions available, shafts are supplied assembled</li> <li>• Drive shaft is not replaceable</li> </ul>   |
| Actuator fixing                | Mounting holes on the lower side of the housing (shaft side), such as actuators SQM45 / SQM48 using M5 screws, or alternatively as actuators SQM10 / SQM20 front mounting using M5 self-tapping screws (see chapter <i>Dimensions</i> ).  |

**Type summary** (other types on request)

Article no.	Type	Direction of rotation		Torque <sup>1)</sup> / running time <sup>1)</sup> for 90°	PCB						Shaft no.	Regional version		Operating voltage		Potentiometer	
		Counter-clockwise	Clockwise		Electronic version Diagram no.	Switch version Diagram no.	3-position	2-position	No. of switches	No. of relay		EU	US / Canada	AC 120 V	AC 230 V	Double 90°	Double 135°
BPZ:SQM40.025A21	SQM40.025A21	●		2.5 Nm / 5 s	2				4		5	●			●	●	
BPZ:SQM40.065A23	SQM40.065A23	●		2.5 Nm / 5 s		6	●		6		5	●			●		●
BPZ:SQM40.115R11	SQM40.115R11	●		5 Nm / 15 s	1				3		5		●	●		●	
BPZ:SQM40.115R13	SQM40.115R13	●		5 Nm / 15 s	1				3		5		●	●			●
BPZ:SQM40.141A21	SQM40.141A21	●		5 Nm / 15 s	4				3		1	●			●	●	
BPZ:SQM40.144R11	SQM40.144R11	●		5 Nm / 15 s	4				3		4		●	●		●	
BPZ:SQM40.145A21	SQM40.145A21	●		5 Nm / 15 s	4				3		5	●			●	●	
BPZ:SQM40.145R11	SQM40.145R11	●		5 Nm / 15 s	4				3		5		●	●		●	
BPZ:SQM40.155R11	SQM40.155R11	●		5 Nm / 15 s	5				4		5		●	●		●	
BPZ:SQM40.155R13	SQM40.155R13	●		5 Nm / 15 s	5				4		5		●	●			●
BPZ:SQM40.161A20	SQM40.161A20	●		5 Nm / 15 s		6	●		6		1	●			●		
BPZ:SQM40.165A20	SQM40.165A20	●		5 Nm / 15 s		6	●		6		5	●			●		
BPZ:SQM40.165A21	SQM40.165A21	●		5 Nm / 15 s		6	●		6		5	●			●	●	
BPZ:SQM40.165R11	SQM40.165R11	●		5 Nm / 15 s		6	●		6		5		●	●		●	
BPZ:SQM40.171A20	SQM40.171A20	●		5 Nm / 15 s		7		●	5	1	1	●			●		
BPZ:SQM40.175A21	SQM40.175A21	●		5 Nm / 15 s		7		●	5	1	5	●			●	●	
BPZ:SQM40.185R11	SQM40.185R11	●		5 Nm / 15 s		8	●		6		5		●	●		●	
BPZ:SQM40.215R11	SQM40.215R11	●		10 Nm / 30 s	1				3		5		●	●		●	
BPZ:SQM40.215R13	SQM40.215R13	●		10 Nm / 30 s	1				3		5		●	●			●

Type summary (other types on request) (cont'd)

Article no.	Type	Direction of rotation		Torque <sup>1)</sup> / running time <sup>1)</sup> for 90°	PCB						Shaft no.	Regional version		Operating voltage		Potentiometer	
		Counter-clockwise	Clockwise		Electronic version Diagram no.	Switch version Diagram no.	3-position	2-position	No. of switches	No. of relay		EU	US / Canada	AC 120 V	AC 230 V	Double 90°	Double 135°
BPZ:SQM40.235A20	SQM40.235A20	●		10 Nm / 30 s		3		●	4	3	5	●			●		
BPZ:SQM40.241A21	SQM40.241A21	●		10 Nm / 30 s	4				3		1	●			●	●	
BPZ:SQM40.241R11	SQM40.241R11	●		10 Nm / 30 s	4				3		1		●	●		●	
BPZ:SQM40.244A21	SQM40.244A21	●		10 Nm / 30 s	4				3		4	●			●	●	
BPZ:SQM40.244R11	SQM40.244R11	●		10 Nm / 30 s	4				3		4		●	●		●	
BPZ:SQM40.245A11	SQM40.245A11	●		10 Nm / 30 s	4				3		5	●		●		●	
BPZ:SQM40.245A21	SQM40.245A21	●		10 Nm / 30 s	4				3		5	●			●	●	
BPZ:SQM40.245R11	SQM40.245R11	●		10 Nm / 30 s	4				3		5		●	●		●	
BPZ:SQM40.247A21	SQM40.247A21	●		10 Nm / 30 s	4				3		7	●			●	●	
BPZ:SQM40.255A21	SQM40.255A21	●		10 Nm / 30 s	5				4		5	●			●	●	
BPZ:SQM40.255R11	SQM40.255R11	●		10 Nm / 30 s	5				4		5		●	●		●	
BPZ:SQM40.255R13	SQM40.255R13	●		10 Nm / 30 s	5				4		5		●	●			●
BPZ:SQM40.261A20	SQM40.261A20	●		10 Nm / 30 s		6	●		6		1	●			●		
BPZ:SQM40.261A21	SQM40.261A21	●		10 Nm / 30 s		6	●		6		1	●			●	●	
BPZ:SQM40.261R11	SQM40.261R11	●		10 Nm / 30 s		6	●		6		1		●	●		●	
BPZ:SQM40.265A11	SQM40.265A11	●		10 Nm / 30 s		6	●		6		5	●		●		●	
BPZ:SQM40.265A20	SQM40.265A20	●		10 Nm / 30 s		6	●		6		5	●			●		
BPZ:SQM40.265A21	SQM40.265A21	●		10 Nm / 30 s		6	●		6		5	●			●	●	
BPZ:SQM40.265R11	SQM40.265R11	●		10 Nm / 30 s		6	●		6		5		●	●		●	
BPZ:SQM40.267A20	SQM40.267A20	●		10 Nm / 30 s		6	●		6		7	●			●		
BPZ:SQM40.271A20	SQM40.271A20	●		10 Nm / 30 s		7		●	5	1	1	●			●		
BPZ:SQM40.274R10	SQM40.274R10	●		10 Nm / 30 s		7		●	5	1	4		●	●			

**Type summary** (other types on request) (cont'd)

Article no.	Type	Direction of rotation		Torque <sup>1)</sup> / running time <sup>1)</sup> for 90°	PCB						Shaft no.	Regional version		Operating voltage		Potentiometer	
		Counter-clockwise	Clockwise		Electronic version Diagram no.	Switch version Diagram no.	3-position	2-position	No. of switches	No. of relay		EU	US / Canada	AC 120 V	AC 230 V	Double 90°	Double 135°
BPZ:SQM40.275A20	SQM40.275A20	●		10 Nm / 30 s		7		●	5	1	5	●			●		
BPZ:SQM40.275A21	SQM40.275A21	●		10 Nm / 30 s		7		●	5	1	5	●			●	●	
BPZ:SQM40.275R10	SQM40.275R10	●		10 Nm / 30 s		7		●	5	1	5		●	●			
BPZ:SQM40.281A20	SQM40.281A20	●		10 Nm / 30 s		8	●		6		1	●			●		
S55452-D305-A100	SQM40.285A20	●		10 Nm / 30 s		8	●		6		5	●			●		
S55452-D309-A100	SQM40.285A23	●		10 Nm / 30 s		8	●		6		5	●			●		●
BPZ:SQM40.285R11	SQM40.285R11	●		10 Nm / 30 s		8	●		6		5		●	●		●	
BPZ:SQM40.317A23	SQM40.317A23	●		18 Nm / 65 s	1				3		7	●			●		●
BPZ:SQM40.317R11	SQM40.317R11	●		18 Nm / 65 s	1				3		7		●	●		●	
BPZ:SQM40.317R13	SQM40.317R13	●		18 Nm / 65 s	1				3		7		●	●			●
BPZ:SQM40.357R11	SQM40.357R11	●		18 Nm / 65 s	5				4		7		●	●		●	
BPZ:SQM40.357R13	SQM40.357R13	●		18 Nm / 65 s	5				4		7		●	●			●
S55452-D301-A100	SQM40.367A10	●		18 Nm / 65 s		6	●		6		7	●		●			
BPZ:SQM40.387A20	SQM40.387A20	●		18 Nm / 65 s		8	●		6		7	●			●		
BPZ:SQM40.387A23	SQM40.387A23	●		18 Nm / 65 s		8	●		6		7	●			●		●
BPZ:SQM40.387R11	SQM40.387R11	●		18 Nm / 65 s		8	●		6		7		●	●		●	
S55452-D314-A100	SQM41.075A20		●	2,5 Nm / 5 s		7		●	5		5	●			●		
BPZ:SQM41.141A21	SQM41.141A21		●	5 Nm / 15 s	4				3		1	●			●	●	
BPZ:SQM41.145A21	SQM41.145A21		●	5 Nm / 15 s	4				3		5	●			●	●	
BPZ:SQM41.165R11	SQM41.165R11		●	5 Nm / 15 s		6	●		6		5		●	●		●	
S55452-D304-A100	SQM41.181A20		●	5 Nm / 15 s		8	●		6		1	●			●		



Type summary (other types on request) (cont'd)

Article no.	Type	Direction of rotation		Torque <sup>1)</sup> / running time <sup>1)</sup> for 90°	PCB						Shaft no.	Regional version		Operating voltage		Potentiometer	
		Counter-clockwise	Clockwise		Electronic version Diagram no.	Switch version Diagram no.	3-position	2-position	No. of switches	No. of relay		EU	US / Canada	AC 120 V	AC 230 V	Double 90°	Double 135°
BPZ:SQM41.185R11	SQM41.185R11		●	5 Nm / 15 s		8	●		6		5		●	●		●	
S55452-D312-A100	SQM41.214R11		●	10 Nm / 30 s	1				3		4		●	●		●	
S55452-D307-A100	SQM41.215R13		●	10 Nm / 30 s	1				3		5		●	●			●
BPZ:SQM41.241A21	SQM41.241A21		●	10 Nm / 30 s	4				3		1	●			●	●	
BPZ:SQM41.241R11	SQM41.241R11		●	10 Nm / 30 s	4				3		1		●	●		●	
BPZ:SQM41.244R11	SQM41.244R11		●	10 Nm / 30 s	4				3		4		●	●		●	
BPZ:SQM41.245A11	SQM41.245A11		●	10 Nm / 30 s	4				3		5	●		●		●	
BPZ:SQM41.245A21	SQM41.245A21		●	10 Nm / 30 s	4				3		5	●			●	●	
BPZ:SQM41.245R11	SQM41.245R11		●	10 Nm / 30 s	4				3		5		●	●		●	
BPZ:SQM41.254R11	SQM41.254R11		●	10 Nm / 30 s	5				4		4		●	●		●	
S55452-D305-A100	SQM41.255R11		●	10 Nm / 30 s	5				4		5		●	●		●	
BPZ:SQM41.261A11	SQM41.261A11		●	10 Nm / 30 s		6	●		6		1	●		●		●	
BPZ:SQM41.261A21	SQM41.261A21		●	10 Nm / 30 s		6	●		6		1	●			●	●	
BPZ:SQM41.261R11	SQM41.261R11		●	10 Nm / 30 s		6	●		6		1		●	●		●	
BPZ:SQM41.264R11	SQM41.264R11		●	10 Nm / 30 s		6	●		6		4		●	●		●	
BPZ:SQM41.265R11	SQM41.265R11		●	10 Nm / 30 s		6	●		6		5		●	●		●	
BPZ:SQM41.267A21	SQM41.267A21		●	10 Nm / 30 s		6	●		6		7	●			●	●	
BPZ:SQM41.271R10	SQM41.271R10		●	10 Nm / 30 s		7		●	5	1	1		●	●			
BPZ:SQM41.275A21	SQM41.275A21		●	10 Nm / 30 s		7		●	5	1	5	●			●	●	

**Type summary** (other types on request) (cont'd)

Article no.	Type	Direction of rotation		Torque <sup>1)</sup> / running time <sup>1)</sup> for 90°	PCB						Shaft no.	Regional version		Operating voltage		Potentiometer	
		Counter-clockwise	Clockwise		Electronic version Diagram no.	Switch version Diagram no.	3-position	2-position	No. of switches	No. of relay		EU	US / Canada	AC 120 V	AC 230 V	Double 90°	Double 135°
BPZ:SQM41.275R10	SQM41.275R10		●	10 Nm / 30 s		7		●	5	1	5		●	●			
S55452-D313-A100	SQM41.281A20		●	10 Nm / 30 s		8	x		6		1	●			●		
BPZ:SQM41.285R11	SQM41.285R11		●	10 Nm / 30 s		8	●		6		5		●	●		●	
S55452-D310-A100	SQM41.285A23		●	10 Nm / 30 s		8	●		6		1	●			●		
BPZ:SQM41.357A23	SQM41.357A23		●	18 Nm / 65 s	5				4		7	●			●		●
BPZ:SQM41.357R11	SQM41.357R11		●	18 Nm / 65 s	5				4		7		●	●		●	
BPZ:SQM41.367A21	SQM41.367A21		●	18 Nm / 65 s		6	●		6		7	●			●	●	
S55452-D311-A100	SQM41.387A23		●	18 Nm / 65 s		8	●		6		7	●			●		●
BPZ:SQM41.387R11	SQM41.387R11		●	18 Nm / 65 s		8	●		6		7		●	●		●	

1) Specifications apply to ambient temperatures of 23 °C and a mains voltage of AC 120 V or AC 230 V and a mains frequency of 50 Hz.

With a mains frequency of 60 Hz, the running times and torques are approx. 17% less.

## Type summary (cont'd) (other types on request) (cont'd)

---



### Note

Not all types of actuators are available ex stock. Additional versions are available on request.

### Drive shafts:

Type of drive shaft	Torque	Shaft no.
Ø 10 mm, woodruff key as per DIN 6888	Max. 10 Nm	1
□ 9.5 mm, square shaft	Max. 15 Nm	4
Ø 10 mm D type shaft, compatible with SQM45	Max. 10 Nm	5
Ø 14 mm with parallel key as per DIN 6885, compatible with SQM48	Max. 20 Nm	7

## Technical Data

### General unit data

Operating voltage	<ul style="list-style-type: none"> <li>• SQM4x.xxxA1</li> <li>• SQM4x.xxxA2</li> <li>• SQM4x.xxxR1</li> </ul>	<p>AC 120 V -15%/+10%</p> <p>AC 230 V -15%/+10%</p> <p>AC 120 V -15%/+10%</p>
Operating frequency		50...60 Hz $\pm$ 6%
Drive motor		Synchronous motor
Power consumption		10 VA
On time		100%
Operating angle		Between 0° and max. 90° or between 0° and max. 135°, depending on the type
Mounting position		Optional
Degree of protection		IP66, provided adequate cable entries are used
Safety class		I
Mode of operation		Automatic regulator and control unit, type 2B
External overload fuse		Max. 6.3 AT (slow) to DIN EN 60127-2/5
Internal overload fuse		2 AT (slow), depending on the type, non-exchangeable
Cable entry		2 x M16 without thread or 2 x 1/2" NPT thread, depending on the type
Wire cross-sectional area of the connecting wires, including earth terminal (PE)		0.5...2.5 mm <sup>2</sup>
Direction of rotation	<ul style="list-style-type: none"> <li>• SQM40</li> <li>• SQM41</li> </ul>	Facing the shaft end (mounting surface): Counterclockwise (CCW) Clockwise (CW)
Torque		2.5 Nm / 5 Nm / 10 Nm / 18 Nm, depending on type <sup>1)</sup>
		1) Specifications apply to ambient temperatures of 23 °C and a mains voltage of AC 120 V or AC 230 V and a mains frequency of 50 Hz. At a mains frequency of 60 Hz, the running times and torques are reduced by approximately 17%.
Torque tolerance		-25%
		Each valid at the tolerance limits of temperature and operating voltage
Holding torque		50% of the torque for types with 5 Nm, 10 Nm, and 18 Nm torque
		36% of the torque for types with 2.5 Nm torque
Running time		5 s, 15 s, 30 s and 65 s, depending on type <sup>1)</sup>
		1) Specifications apply to ambient temperatures of 23 °C and a mains voltage of AC 120 V or AC 230 V and a mains frequency of 50 Hz. At a mains frequency of 60 Hz, the running times and torques are reduced by approximately 17%.
Running time tolerance		$\pm$ 10%
Pause time at change in direction of rotation, zero-current state		>100 ms
End and auxiliary switches	<ul style="list-style-type: none"> <li>• Type</li> <li>• Switching voltage</li> <li>• Switching capacity</li> </ul>	<p>To DIN 41636</p> <p>AC 24...250 V</p> <p>See specifications in chapter <i>Connection diagrams</i></p>

## Technical Data (cont'd)

General unit data	Number of end switches	2
	Number of auxiliary switches	Max. 4, depending on type
	Drive shaft	Supplied as standard, non-exchangeable
	Weight	Approx. 2 kg
	Temperature of the mounting surface	Max. 60 °C
	Rated surge voltage	Overvoltage category III in accordance with DIN EN 60730-1 chapter 20 Pollution degree 2
	Backlash between the actuator motor and actuator shaft	
	<ul style="list-style-type: none"> <li>ex works</li> <li>after 250,000 cycles</li> </ul>	<ul style="list-style-type: none"> <li>&lt;1°</li> <li>&lt;1.2°</li> </ul>
	Lifetime	250,000 start cycles (close ⇒ open ⇒ close) under load with the rated torque in the entire rotation angle range. 2,000,000 control cycles under load with 75% of rated torque in rotation angle range of 10°

## Analog inputs

<b>General</b>	
Linearity	<5% of the control range
Control range	0...90° or 0...135°, depending on type
<b>Voltage setpoint</b>	DC 2...10 V
X1-1 (U-IN), X1-2 (GND)	
<ul style="list-style-type: none"> <li>U<sub>min</sub></li> <li>U<sub>max</sub></li> </ul>	<ul style="list-style-type: none"> <li>DC 2 V</li> <li>DC 10 V</li> </ul>
Input impedance	≥5 kΩ
<b>Current setpoint</b>	DC 4...20 mA
X1-3 (I-IN), X1-2 (GND)	
<ul style="list-style-type: none"> <li>I<sub>min</sub></li> <li>I<sub>max</sub></li> </ul>	<ul style="list-style-type: none"> <li>DC 4 mA</li> <li>DC 20 mA</li> </ul>
Input impedance	≤500 Ω
<b>Impedance setpoint</b>	0...135 Ω
X1-4, X1-5, X1-6 (GND)	
<ul style="list-style-type: none"> <li>R<sub>Nominal</sub></li> </ul>	135 Ω ±5%

## For use in North America

<b>Cross-sectional area of the power supply lines</b>	
SQM4x.x1xxxx / SQM4x.x4xxxx / SQM4x.x5xxxx, (X2), (PE)	Class 1, min. AWG 16 Suited for 105 °C
SQM4x.x6xxxx / SQM4x.x7xxxx / SQM4x.x8xxxx, (X1)/(X2)/(X3), (PE)	Max. 2.5 mm <sup>2</sup> or AWG 14
SQM4x.x1xxxx / SQM4x.x2xxxx / SQM4x.x4xxxx / SQM4x.x5xxxx (X1)	Class 2, min. AWG 22 Suited for 105 °C Max. 1 mm <sup>2</sup> or AWG 18
Outdoor use	



**Attention!**  
Waterproof cable conduits and cable glands are required (e.g. type DWTT/7 or QCRV2/8)

## Technical Data (cont'd)

Environmental conditions	<b>Storage</b>	DIN EN 60721-3-1:1997
	Climatic conditions	Class 1K3
	Mechanical conditions	Class 1M2
	Temperature range	-20...60 °C
	Humidity	<95% r.h.
	<b>Transport</b>	DIN EN 60721-3-2:1997
	Climatic conditions	Class 2K3
	Mechanical conditions	Class 2M2
	Temperature range	-20...60 °C
	Humidity	<95% r.h.
	<b>Operation</b>	DIN EN 60721-3-3:1995
	Climatic conditions	Class 3K5
	Mechanical conditions	Class 3M4
	Temperature range	-20...60 °C -15...+60 °C for 18 Nm design
	Humidity	<95% r.h.
Installation altitude	Max. 2,000 m above sea level	



### Notice!

Condensation, formation of ice, and ingress of water are not permitted. If this is not observed, there is a risk of loss of safety functions and a risk of electric shock.

Conductive plastic potentiometer

Resistance	2*1000 Ω double potentiometer with separated resistance tracks
Operating voltage	DC 10 V
Permissible hysteresis	0.3% of 90° or of 135°, depending on type
Total resistance tolerance	±20%
Effective angular rotation	90° or 135°, depending on type
Terminal strip	Triple-pole
For cross-sectional areas of	0.5...1 mm <sup>2</sup>
Wiper current rating	Max. 100 μA
Transfer resistance of wiper contact	Max. $R_{ü} \leq 100 \Omega$
Linearity (referred to $R_{ges} = 1000 \Omega$ )	±1%
Smoothness (alpha = 10°) / microlinearity	<0.5%
Life cycle	Approx. 2 million positioning cycles
Temperature coefficient	0.4 Ω/K

## Technical Data (cont'd)

Conductive plastic potentiometer connection diagram

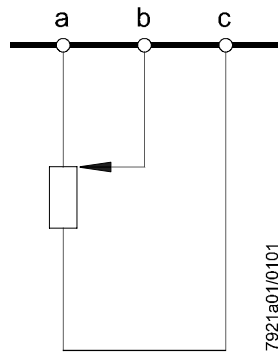

Potentiometer drawn in start position (as supplied).

Terminal markings:

a = high end of potentiometer

b = potentiometer wiper

c = low end of potentiometer

Apply operating voltage only on terminals «a» and «c». Conductive plastic potentiometers can be destroyed if operating voltage is applied incorrectly between «a → b» or «b → c».

The polarity of the potentiometer end pickups «a → c» must be observed in order to achieve the correct signal direction to the potentiometer wiper «b».

If the ASZ22.32 potentiometer specified for 90° is operated outside of the effective range of angular rotation of 90°, no valid signal will be present at the wiper contact (interrupted circuit). This can happen if the switch position of the switching cam I for high-fire is configured for over 90°.

The 90° version ASZ22.32 can be used for both directions of rotation, SQM40 (counterclockwise) and SQM41 (clockwise).

The 135° versions ASZ22.34 and ASZ22.35 are each intended for a particular direction of rotation.

The direction of rotation of the potentiometer must correspond with the direction of rotation of the actuator as follows:

- ASZ22.34 can only be used with SQM41 (clockwise)
- ASZ22.35 can only be used with SQM40 (counterclockwise)



**Note!**  
Ensure correct direction of rotation!

**SQM40 (left, CCW)**

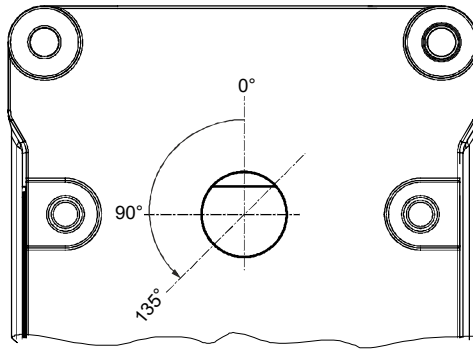

**SQM41 (right, CW)**

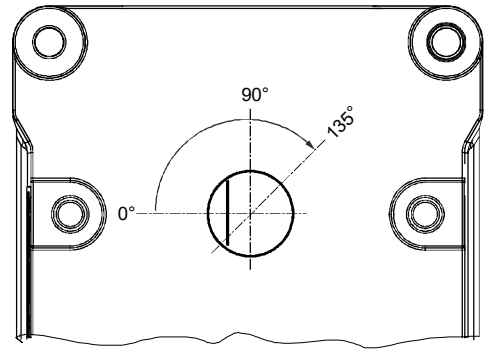

**SQM40 position indication**

External angle scale  
Marking in slot shape

**SQM41 position indication**

Internal angle scale  
Marking in arrow shape

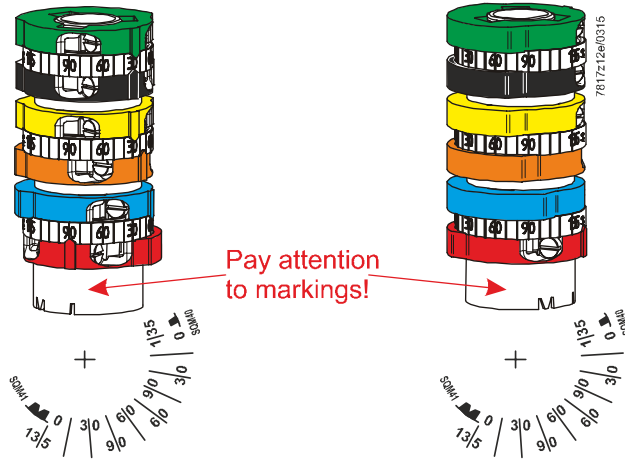

**Note!**  
The setting of the switch positions must be checked before commissioning.



SQM4x.x1xxxx

Electronic version with independent high-fire and low-fire feedback



**Note!**  
For the sake of clarity, the plug-in contacts do not appear in sequential order in the circuit diagram. Consecutive numbers are printed on the unit, however, e.g. 1...7.

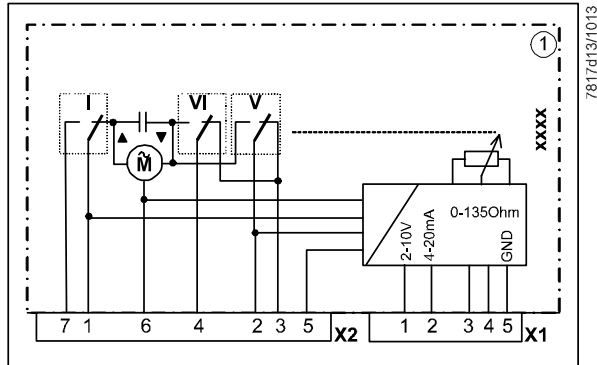

**Mains voltage terminals**      **Dimensioning**

Mains voltage terminals	Dimensioning
X2-1    Open (I)	Input    AC 120 V / AC 230 V / max. 1 A, cosφ >0.9 *
X2-2    Move to low-fire (V)	Input    AC 120 V / AC 230 V / max. 1 A, cosφ >0.9 *
X2-3    Low-fire position reached (V)	Output    AC 120 V / AC 230 V / max. 10 mA, cosφ >0.9
X2-4    Close / ignition (VI)	Input    AC 120 V / AC 230 V / max. 1 A, cosφ >0.9
X2-5    Controller release	Input    AC 120 V / AC 230 V / max. 60 mA / 30 mA
X2-6    Neutral	Input    AC 120 V / AC 230 V / max. 60 mA / 30 mA
X2-7    'OPEN' position reached (I)	Output    AC 120 V / AC 230 V / max. 10 mA, cosφ >0.9

**Mains voltage terminals**      **Dimensioning**

Mains voltage terminals	Dimensioning
X1-1    2...10 V	Input    max. DC 10 V / to X1-5
X1-2    4...20 mA	Input    max. 20 mA / to X1-5
X1-3    0...135 Ω 1	Input    ---
X1-4    0...135 Ω 2	Input    ---
X1-5    0...135 Ω 3 (GND)	Input    ---

\* Only the control lines to the burner controls or to the control unit may be connected at the marked terminals. It is not permitted to connect additional external loads, such as signal lamps.

SQM4x.x1xxxx

Electronic version with independent feedback for high-fire and low-fire



**Note!**  
The setting of the switch positions must be checked before commissioning.

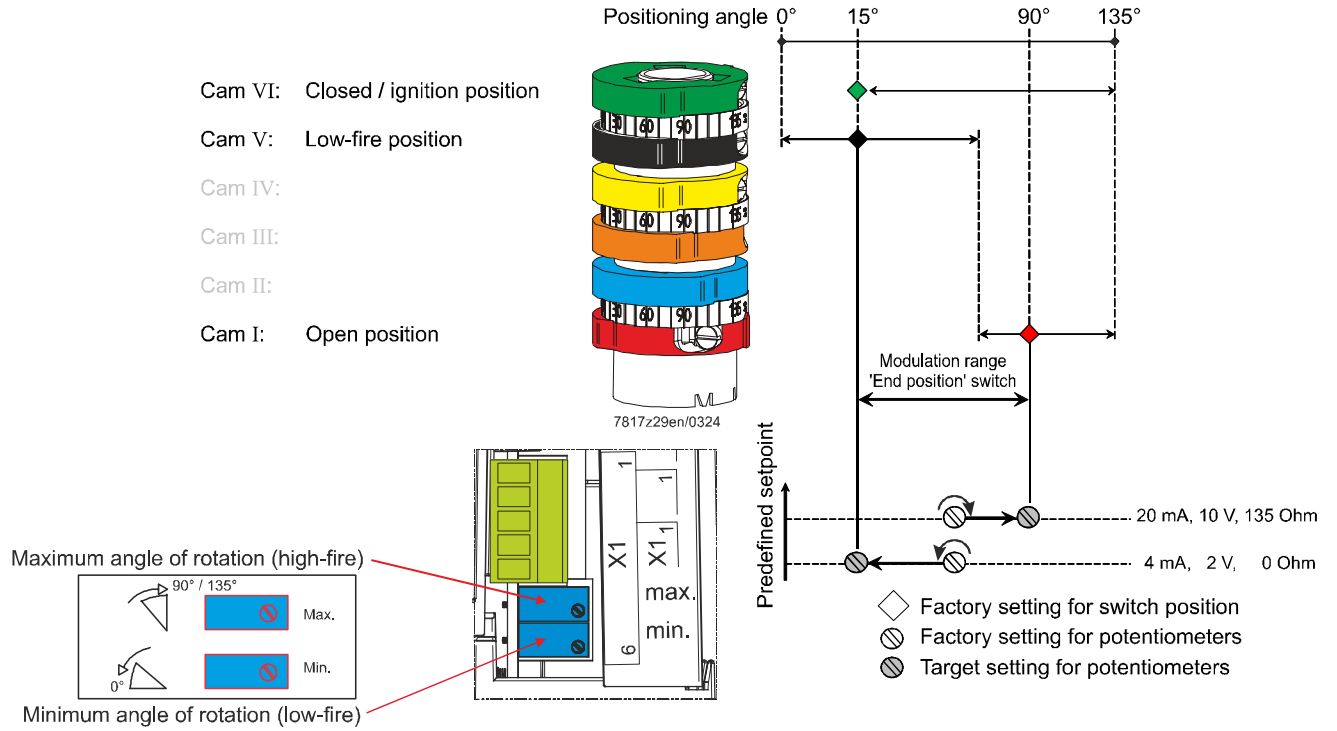

Modulation always takes place between high-fire (cam I) and low-fire (cam V). It is also possible to limit the modulation range via 2 potentiometers and thus adjust the characteristic curve for the dependency between the predefined setpoint and the angle of rotation.



**Note!**  
Direction of rotation of the potentiometer setting.  
The direction of rotation of the potentiometer setting must be observed during commissioning.

### SQM4x.x1xxxx

Setting range /  
modulation range

Adjust the range of the analog signal to match the switch positions (minimum and maximum position):

1. Set cam (I) to the required high-fire position
2. Set cam (V) to the required low-fire position
3. Apply predefined setpoint for the high-fire position at the analog input (depending on the type and application, the predefined setpoint can be applied in terms of current (4...20 mA), voltage (2...10 V) or resistance (0...135 Ohm))
4. Set the potentiometer for the maximum angle of rotation (default setting is the center position):  
If the SQM40/SQM41 has not yet reached the maximum angle of rotation, the potentiometer must be turned clockwise until the predefined setpoint, the current angle position of the SQM40/SQM41, and the shutdown by the cam switch all match  
OR  
If the SQM40/SQM41 has already reached the maximum angle of rotation, the potentiometer must be turned counterclockwise until the predefined setpoint, the current angle position of the SQM40/SQM41, and the shutdown by the cam switch all match
5. Apply predefined setpoint for the low-fire position at the analog input (depending on the type and application, the predefined setpoint is 4 mA, 2 V, or 0 Ohm)
6. Set the potentiometers for the minimum angle of rotation:  
If the SQM40/SQM41 has not yet reached the minimum angle of rotation, the potentiometer must be turned counterclockwise until the predefined setpoint, the current angle position of the SQM40/SQM41, and the shutdown by the cam switch all match  
OR  
If the SQM40/SQM41 has already reached the minimum angle of rotation, the potentiometer must be turned clockwise until the setpoint specification, the current angle position of the SQM40/SQM41, and the shutdown by the cam switch all match
7. The two potentiometers are electrically coupled with each other. This means that a change to one potentiometer has a retroactive effect on the setting value of the other potentiometer. It is therefore necessary to check the end positions for the minimum and maximum predefined setpoint and repeat steps 4 to 7 if necessary.

SQM4x.x2xxxx

Electronic version, only for types with 5 seconds running time



**Note!**

For the sake of clarity, the plug-in contacts do not appear in sequential order in the circuit diagram. Consecutive numbers are printed on the unit, however, e.g. 1...7.

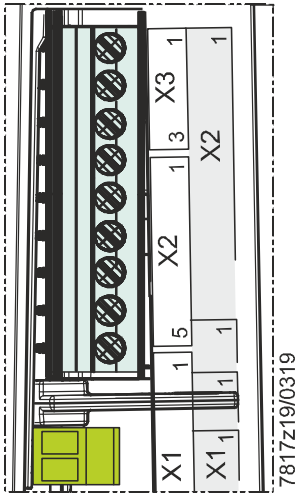
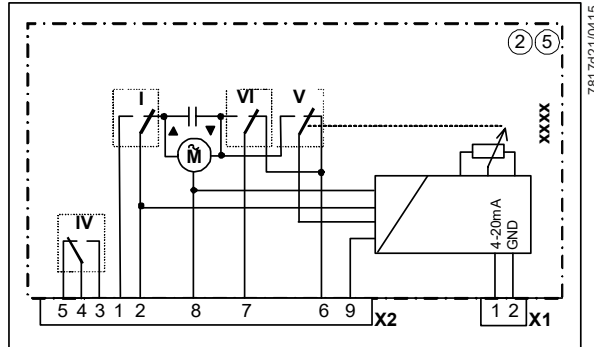

Mains voltage terminals			Dimensioning	
X2-1	'OPEN' position reached (I)	Output	AC 120 V / AC 230 V / max. 10 mA, $\cos\phi > 0.9$	
X2-2	Open, high-fire (I)	Input	AC 120 V / AC 230 V / max. 1 A, $\cos\phi > 0.9$ *	
X2-3	Auxiliary switch AUX (IV) NO contact	Output	AC 120 V / AC 230 V / max. 1 A, $\cos\phi > 0.9$	
X2-4	Auxiliary switch AUX (IV)	Input	AC 120 V / AC 230 V / max. 1 A, $\cos\phi > 0.9$	
X2-5	Auxiliary switch AUX (IV) NC opener	Output	AC 120 V / AC 230 V / max. 1 A, $\cos\phi > 0.9$	
X2-6	Low-fire position / ignition load position reached (V / VI)	Output	AC 120 V / AC 230 V / max. 10 mA, $\cos\phi > 0.9$	
X2-7	Close / ignition (VI)	Input	AC 120 V / AC 230 V max. 1 A, $\cos\phi > 0.9$ *	
X2-8	Neutral	Input	AC 120 V / AC 230 V max. 60 mA / 30 mA	
X2-9	Controller release	Input	AC 120 V / AC 230 V max. 60 mA / 30 mA	
Low-voltage terminals			Dimensioning	
X1-1	4...20 mA	Input	max. 20 mA / to X1-2	
X1-2	GND	Input	---	

\* Only the control lines to the burner controls or to the control unit may be connected at the marked terminals. It is not permitted to connect additional external loads, such as signal lamps.



**Please note!**

The auxiliary switch IV is not suitable for controlling the fuel valves according to the standard.



**Note!**  
The setting of the switch positions must be checked before commissioning.

- Cam VI: Closed / ignition position
- Cam V: Low-fire position
- Cam IV: Auxiliary switch
- Cam III:
- Cam II:
- Cam I: High-fire / open position

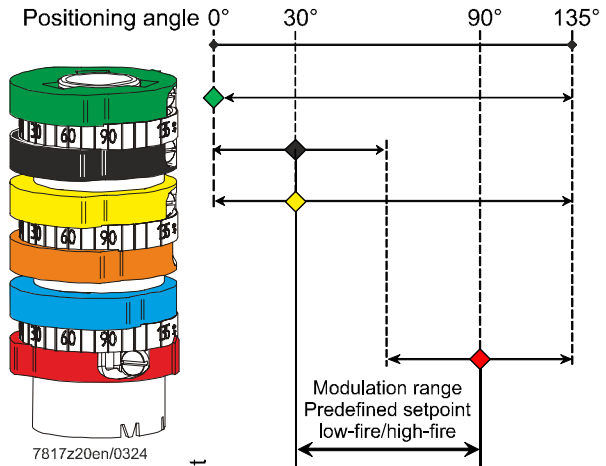

7817z20en/0324

Maximum angle of rotation (high-fire)

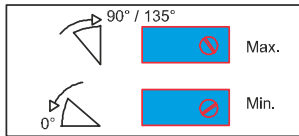

Minimum angle of rotation (low-fire)

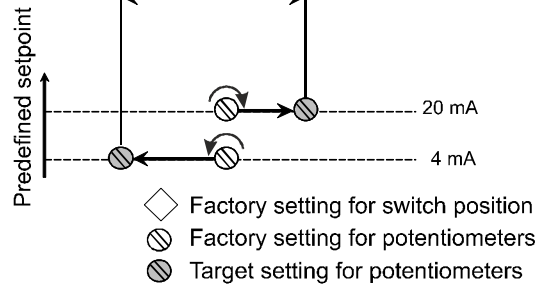
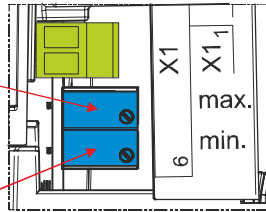

### SQM4x.x2xxxx

Setting range /  
modulation range

Adjust the range of the analog signal to match the switch positions (minimum and maximum position):

1. Set cam (I) to the required high-fire position
2. Set cam (V) to the required low-fire position
3. Apply predefined setpoint for the high-fire position at the analog input (depending on the type and application, the predefined setpoint can be applied in terms of current (4...20 mA), voltage (2...10 V) or resistance (0...135 Ohm))
4. Set the potentiometer for the maximum angle of rotation (default setting is the center position):  
If the SQM40/SQM41 has not yet reached the maximum angle of rotation, the potentiometer must be turned clockwise until the predefined setpoint, the current angle position of the SQM40/SQM41, and the shutdown by the cam switch all match  
OR  
If the SQM40/SQM41 has already reached the maximum angle of rotation, the potentiometer must be turned counterclockwise until the predefined setpoint, the current angle position of the SQM40/SQM41, and the shutdown by the cam switch all match
5. Apply predefined setpoint for the low-fire position at the analog input (depending on the type and application, the predefined setpoint is 4 mA, 2 V, or 0 Ohm)
6. Set the potentiometers for the minimum angle of rotation:  
If the SQM40/SQM41 has not yet reached the minimum angle of rotation, the potentiometer must be turned counterclockwise until the predefined setpoint, the current angle position of the SQM40/SQM41, and the shutdown by the cam switch all match  
OR  
If the SQM40/SQM41 has already reached the minimum angle of rotation, the potentiometer must be turned clockwise until the setpoint specification, the current angle position of the SQM40/SQM41, and the shutdown by the cam switch all match
7. The two potentiometers are electrically coupled with each other. This means that a change to one potentiometer has a retroactive effect on the setting value of the other potentiometer. It is therefore necessary to check the end positions for the minimum and maximum predefined setpoint and repeat steps 4 to 7 if necessary.

SQM4x.x3xxxx

2-position version with 2 end switches and 2 auxiliary switches, 3 relays



**Note!**  
For the sake of clarity, the plug-in contacts do not appear in sequential order in the circuit diagram. Consecutive numbers are printed on the unit, however, e.g. 1...7.

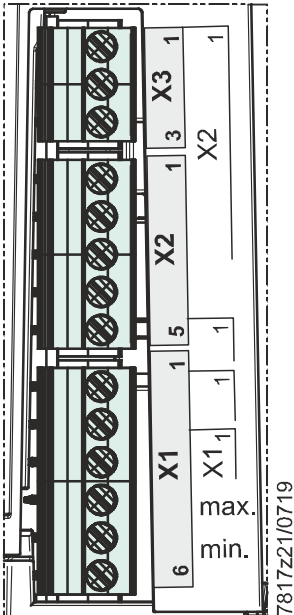
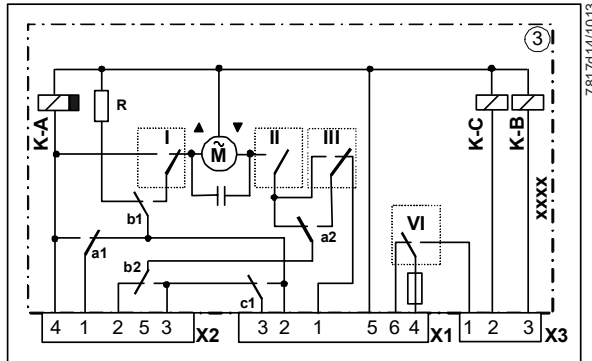

Mains voltage terminals			Dimensioning
X3-1	Auxiliary switch AUX (VI) NO contact	Output	AC 120 V / AC 230 V / max. 1 A, $\cos\phi > 0.9$ **
X3-2	Open (I) / close (II), changeover relay K-C	Input	AC 120 V / AC 230 V / max. 1 A, $\cos\phi > 0.9$
X3-3	Operation, changeover relay K-B	Input	AC 120 V / AC 230 V / max. 1 A, $\cos\phi > 0.9$
X2-1	Fan supply voltage	Input	AC 120 V / AC 230 V / max. 1 A, $\cos\phi > 0.9$
X2-2	Mains voltage, close	Input	AC 120 V / AC 230 V / max. 1 A, $\cos\phi > 0.9$
X2-3	Low-fire controller	Input	AC 120 V / AC 230 V / max. 1 A, $\cos\phi > 0.9$
X2-4	Fan motor	Output	AC 120 V / AC 230 V / max. 1 A, $\cos\phi > 0.9$
X2-5	Free	---	---
X1-1	Ignition position reached (III)	Output	120 V AC / 230 V AC / max. 1 A, $\cos\phi > 0.9$
X1-2	Controller, open	Input	AC 120 V / AC 230 V / max. 1 A, $\cos\phi > 0.9$
X1-3	Controller release	Input	AC 120 V / AC 230 V / max. 1 A, $\cos\phi > 0.9$
X1-4	Auxiliary switch AUX (VI)	Input	AC 120 V / AC 230 V / max. 1 A, $\cos\phi > 0.9$ **
X1-5	Neutral	Input	AC 120 V / AC 230 V / max. 1 A, $\cos\phi > 0.9$
X1-6	Auxiliary switch AUX (VI) NC opener	Output	AC 120 V / AC 230 V / max. 1 A, $\cos\phi > 0.9$ **



**Please note!**  
\*\* When connecting a fuel valve: Max. 0.3 A,  $\cos\phi > 0.8$  inductive.

**Circuit diagrams and connection terminals (continued)**

**SQM4x.x3xxxx**

2-position version with 2 end switches and 2 auxiliary switches, 3 relays



**Note!**  
The setting of the switch positions must be checked before commissioning.

- Cam VI: Auxiliary switch
- Cam V:
- Cam IV:
- Cam III: Ignition position
- Cam II: Closed
- Cam I: High-fire / open position

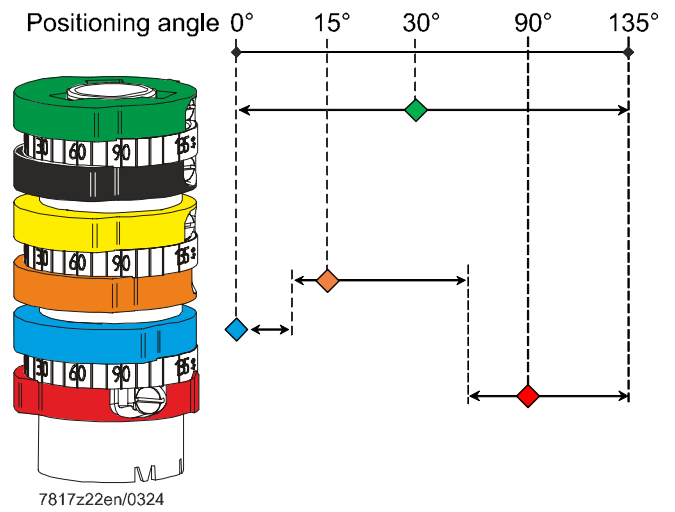

◇ Factory setting for switch position



SQM4x.x4xxxx

Electronic version



**Note!**

For the sake of clarity, the plug-in contacts do not appear in sequential order in the circuit diagram. Consecutive numbers are printed on the unit, however, e.g. 1...7.

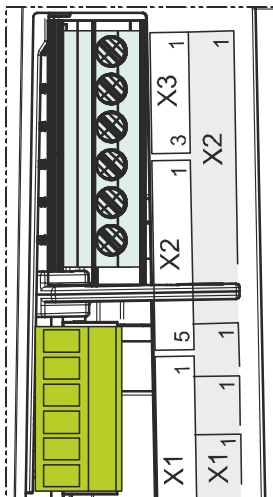
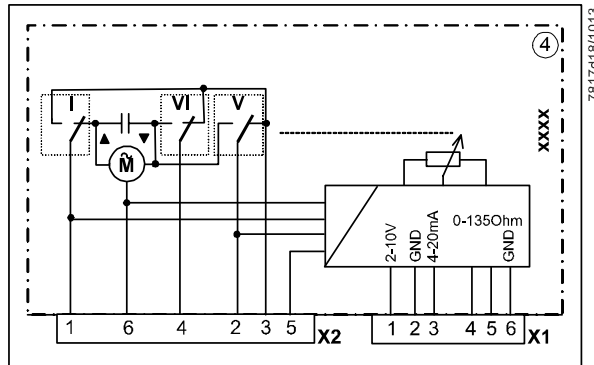

**Mains voltage terminals**

Terminal	Function	Type	Dimensioning
X2-1	Opening (I)	Input	AC 120 V / AC 230 V / max. 1 A, $\cos\phi > 0.9$ *
X2-2	Move to low-fire (V)	Input	AC 120 V / AC 230 V / max. 1 A, $\cos\phi > 0.9$ *
X2-3	Position reached	Output	AC 120 V / AC 230 V / max. 10 mA, $\cos\phi > 0.9$
X2-4	Closing/ignition (VI)	Input	AC 120 V / AC 230 V / max. 1 A, $\cos\phi > 0.9$
X2-5	Controller release	Input	AC 120 V / AC 230 V / max. 60 mA / 30 mA
X2-6	Neutral	Input	AC 120 V / AC 230 V / max. 60 mA / 30 mA

**Low-voltage terminals**

Terminal	Function	Type	Dimensioning
X1-1	2...10 V	Input	max. DC 10 V / to X1-2
X1-2	GND	Input	---
X1-3	4...20 mA	Input	Max. 20 mA to X1-2
X1-4	0...135 $\Omega$ 1	Input	---
X1-5	0...135 $\Omega$ 2	Input	---
X1-6	0...135 $\Omega$ 3 (GND)	Input	---

\* Only the control lines to the burner controls or to the control unit may be connected at the marked terminals. It is not permitted to connect additional external loads, such as signal lamps.



**Note!**  
The setting of the switch positions must be checked before commissioning.

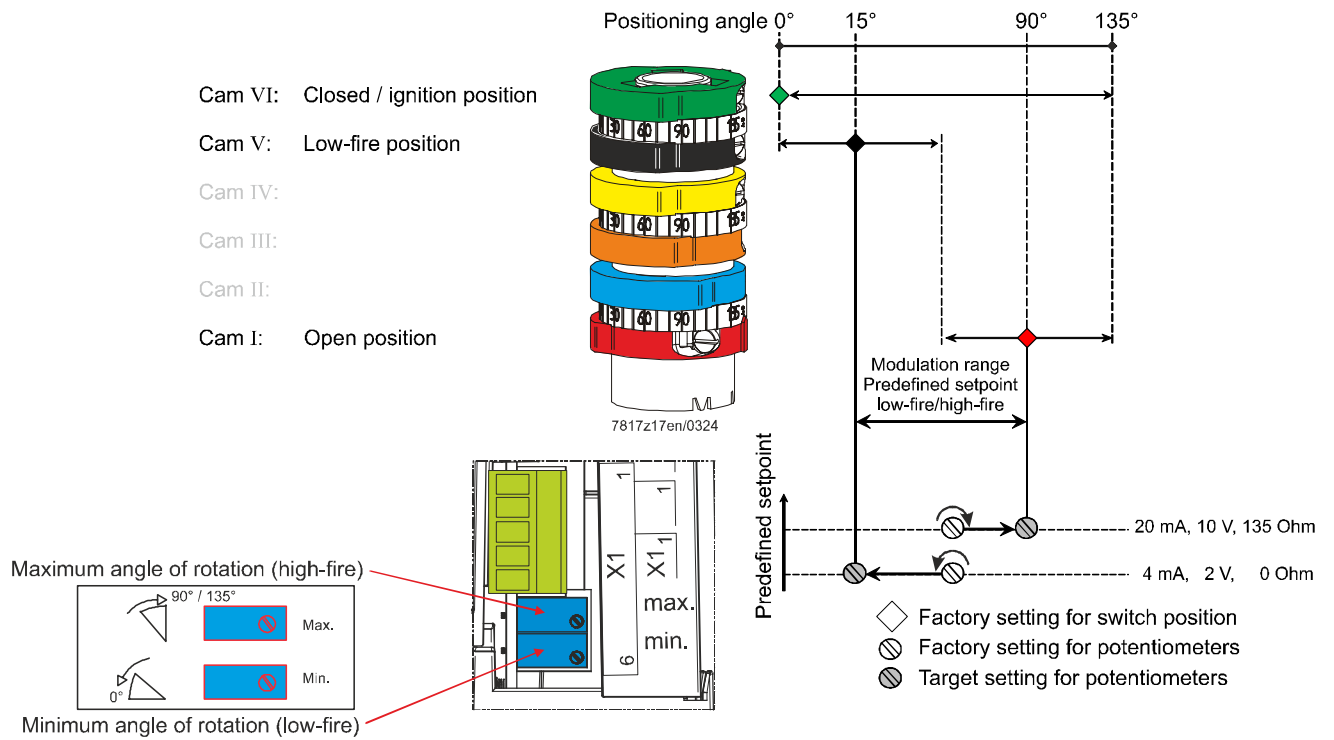

### SQM4x.x4xxxx

Setting range /  
modulation range

Adjust the range of the analog signal to match the switch positions (minimum and maximum position):

1. Set cam (I) to the required high-fire position
2. Set cam (V) to the required low-fire position
3. Apply predefined setpoint for the high-fire position at the analog input (depending on the type and application, the predefined setpoint can be applied in terms of current (4...20 mA), voltage (2...10 V) or resistance (0...135 Ohm))
4. Set the potentiometer for the maximum angle of rotation (default setting is the center position):  
If the SQM40/SQM41 has not yet reached the maximum angle of rotation, the potentiometer must be turned clockwise until the predefined setpoint, the current angle position of the SQM40/SQM41, and the shutdown by the cam switch all match  
OR  
If the SQM40/SQM41 has already reached the maximum angle of rotation, the potentiometer must be turned counterclockwise until the predefined setpoint, the current angle position of the SQM40/SQM41, and the shutdown by the cam switch all match
5. Apply predefined setpoint for the low-fire position at the analog input (depending on the type and application, the predefined setpoint is 4 mA, 2 V, or 0 Ohm)
6. Set the potentiometers for the minimum angle of rotation:  
If the SQM40/SQM41 has not yet reached the minimum angle of rotation, the potentiometer must be turned counterclockwise until the predefined setpoint, the current angle position of the SQM40/SQM41, and the shutdown by the cam switch all match  
OR  
If the SQM40/SQM41 has already reached the minimum angle of rotation, the potentiometer must be turned clockwise until the setpoint specification, the current angle position of the SQM40/SQM41, and the shutdown by the cam switch all match
7. The two potentiometers are electrically coupled with each other. This means that a change to one potentiometer has a retroactive effect on the setting value of the other potentiometer. It is therefore necessary to check the end positions for the minimum and maximum predefined setpoint and repeat steps 4 to 7 if necessary.

SQM4x.x5xxxx

Electronic version with independent auxiliary switch



**Note!**

For the sake of clarity, the plug-in contacts do not appear in sequential order in the circuit diagram. Consecutive numbers are printed on the unit, however, e.g. 1...7.

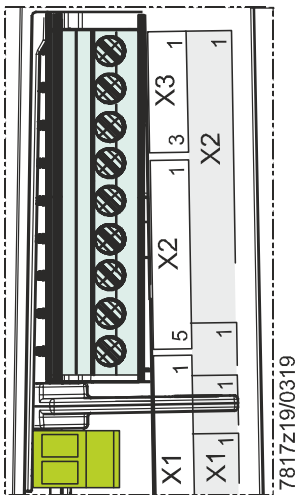
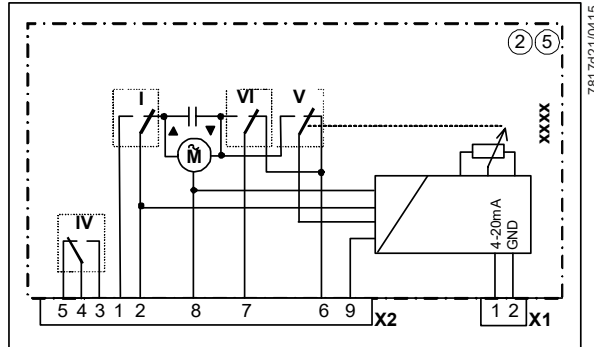

Mains voltage terminals			Dimensioning	
X2-1	'OPEN' position reached (I)	Output	AC 120 V / AC 230 V / max. 10 mA, $\cos\phi > 0.9$	
X2-2	Open / high-fire (I)	Input	AC 120 V / AC 230 V / max. 1 A, $\cos\phi > 0.9$ *	
X2-3	Auxiliary switch AUX (IV) NO contact	Output	AC 120 V / AC 230 V / max. 1 A, $\cos\phi > 0.9$	
X2-4	Auxiliary switch AUX (IV)	Input	AC 120 V / AC 230 V / max. 1 A, $\cos\phi > 0.9$	
X2-5	Auxiliary switch AUX (IV) / NC opener	Output	AC 120 V / AC 230 V / max. 1 A, $\cos\phi > 0.9$	
X2-6	Low-fire position / ignition load position reached (V, VI)	Output	AC 120 V / AC 230 V / max. 10 mA, $\cos\phi > 0.9$	
X2-7	Close / ignition (VI)	Input	AC 120 V / AC 230 V / max. 1 A, $\cos\phi > 0.9$ *	
X2-8	Neutral	Input	AC 120 V / AC 230 V / max. 60 mA / 30 mA	
X2-9	Controller release	Input	AC 120 V / AC 230 V / max. 60 mA / 30 mA	
Low-voltage terminals			Dimensioning	
X1-1	4...20 mA	Input	max. 20 mA / to X1-2	
X1-2	GND	Input	---	

\* Only the control lines to the burner controls or to the control unit may be connected at the marked terminals. It is not permitted to connect additional external loads, such as signal lamps.



**Please note!**

The auxiliary switch IV is not suitable for controlling the fuel valves according to the standard.

SQM4x.x5xxxx

Electronic version with independent auxiliary switch



**Note!**  
The setting of the switch positions must be checked before commissioning.

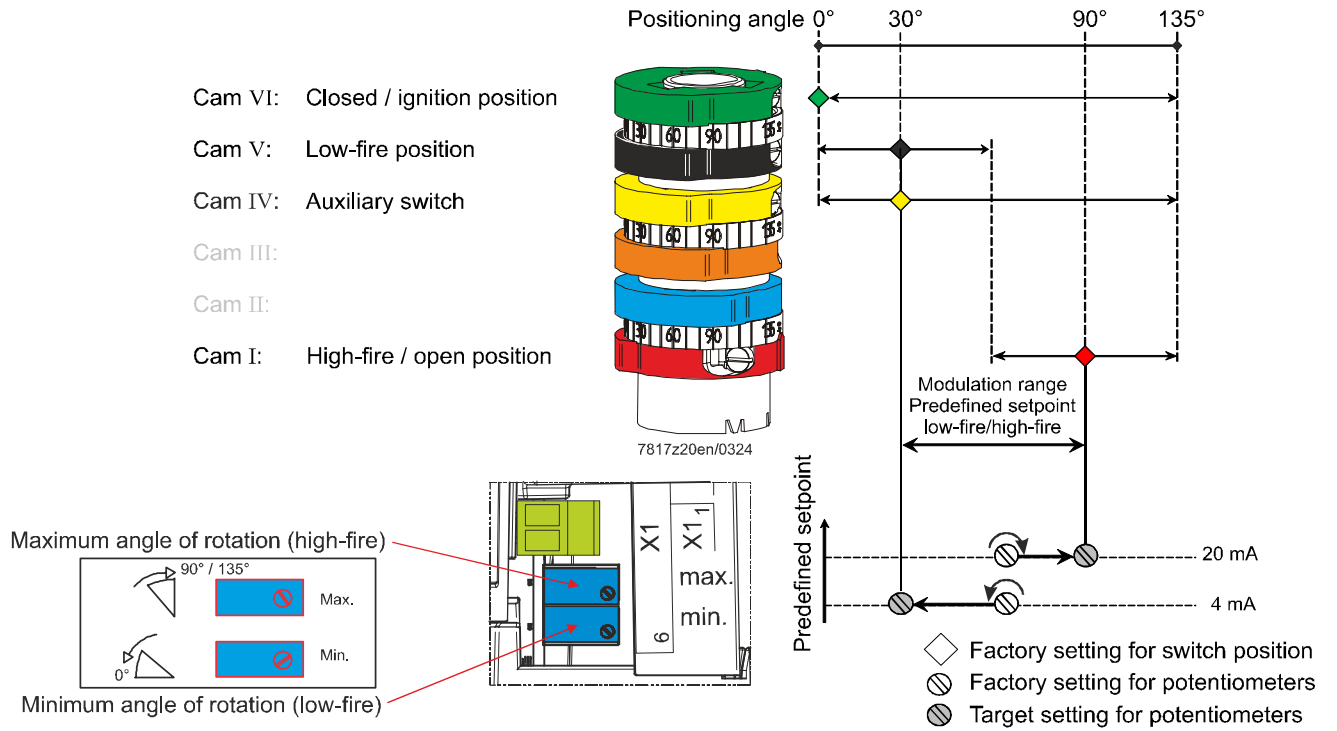

### SQM4x.x5xxxx

Setting range /  
modulation range

Adjust the range of the analog signal to match the switch positions (minimum and maximum position):

1. Set cam (I) to the required high-fire position
2. Set cam (V) to the required low-fire position
3. Apply predefined setpoint for the high-fire position at the analog input (depending on the type and application, the predefined setpoint can be applied in terms of current (4...20 mA), voltage (2...10 V) or resistance (0...135 Ohm))
4. Set the potentiometer for the maximum angle of rotation (default setting is the center position):  
If the SQM40/SQM41 has not yet reached the maximum angle of rotation, the potentiometer must be turned clockwise until the predefined setpoint, the current angle position of the SQM40/SQM41, and the shutdown by the cam switch all match  
OR  
If the SQM40/SQM41 has already reached the maximum angle of rotation, the potentiometer must be turned counterclockwise until the predefined setpoint, the current angle position of the SQM40/SQM41, and the shutdown by the cam switch all match
5. Apply predefined setpoint for the low-fire position at the analog input (depending on the type and application, the predefined setpoint is 4 mA, 2 V, or 0 Ohm)
6. Set the potentiometers for the minimum angle of rotation:  
If the SQM40/SQM41 has not yet reached the minimum angle of rotation, the potentiometer must be turned counterclockwise until the predefined setpoint, the current angle position of the SQM40/SQM41, and the shutdown by the cam switch all match  
OR  
If the SQM40/SQM41 has already reached the minimum angle of rotation, the potentiometer must be turned clockwise until the setpoint specification, the current angle position of the SQM40/SQM41, and the shutdown by the cam switch all match

SQM4x.x6xxxx

3-position version with 2 end switches and 4 auxiliary switches

**Note!**  
 For the sake of clarity, the plug-in contacts do not appear in sequential order in the circuit diagram. Consecutive numbers are printed on the unit, however, e.g. 1...7.

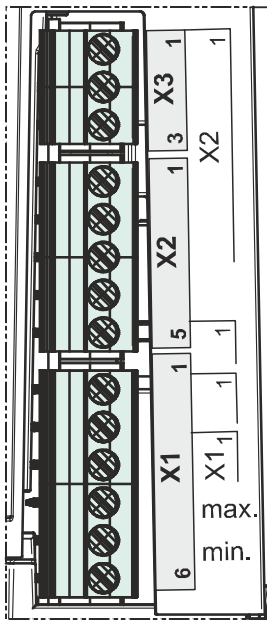
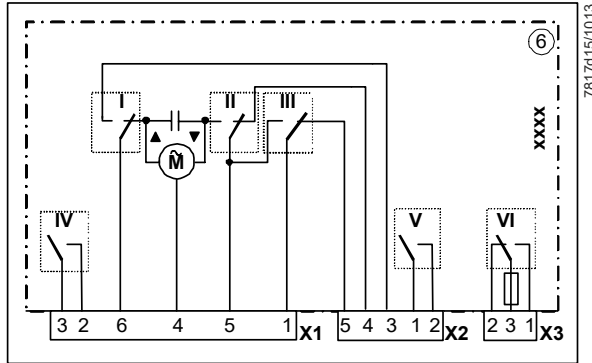

Mains voltage terminals			Dimensioning	
X3-1	Auxiliary switch AUX (VI) NO contact	Output	AC 120 V / AC 230 V / max. 1 A, $\cos\phi > 0.9$ **	
X3-2	Auxiliary switch AUX (VI) NC opener	Output	AC 120 V / AC 230 V / max. 1 A, $\cos\phi > 0.9$ **	
X3-3	Auxiliary switch AUX (VI)	Input	AC 120 V / AC 230 V / max. 1 A, $\cos\phi > 0.9$ **	
X2-1	Auxiliary switch AUX (V)	Input	AC 120 V / AC 230 V / max. 1 A, $\cos\phi > 0.9$	
X2-2	Auxiliary switch AUX (V) NO contact	Output	AC 120 V / AC 230 V / max. 1 A, $\cos\phi > 0.9$	
X2-3	'OPEN' position reached (I)	Output	AC 120 V / AC 230 V / max. 0.3 A, $\cos\phi > 0.8$	
X2-4	'CLOSED' position reached (II)	Output	AC 120 V / AC 230 V / max. 0.3 A, $\cos\phi > 0.8$	
X2-5	Ignition position reached (III)	Output	AC 120 V / AC 230 V / max. 0.3 A, $\cos\phi > 0.8$	
X1-1	Move to ignition position (III)	Input	AC 120 V / AC 230 V / max. 1 A, $\cos\phi > 0.9$	
X1-2	Auxiliary switch AUX (IV) NO contact	Output	AC 120 V / AC 230 V / max. 1 A, $\cos\phi > 0.9$	
X1-3	Auxiliary switch AUX (IV)	Input	AC 120 V / AC 230 V / max. 1 A, $\cos\phi > 0.9$	
X1-4	Neutral	---	AC 120 V / AC 230 V / max. 1 A, $\cos\phi > 0.9$	
X1-5	Closing (II)	Input	AC 120 V / AC 230 V / max. 1 A, $\cos\phi > 0.9$	
X1-6	Opening (I)	Input	AC 120 V / AC 230 V / max. 1 A, $\cos\phi > 0.9$	

**Warning!**  
**Please note!**  
**\*\* When connecting a fuel valve: Max. 0.3 A,  $\cos\phi > 0.8$  inductive.**



**Note!**  
The setting of the switch positions must be checked before commissioning.

- Cam VI: Auxiliary switch
- Cam V: Auxiliary switch
- Cam IV: Auxiliary switch
- Cam III: Ignition position
- Cam II: Closed
- Cam I: High-fire / open position

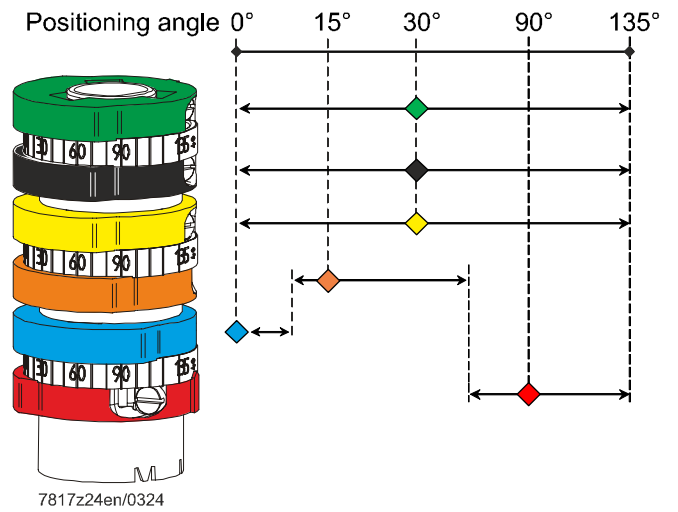

◇ Factory setting for switch position



## Connection diagrams and connection terminals (cont'd)

SQM4x.x7xxxx

2-position version with 2 end switches and 3 auxiliary switches, 1 relay



### Note!

For the sake of clarity, the plug-in contacts do not appear in sequential order in the circuit diagram. Consecutive numbers are printed on the unit, however, e.g. 1...7.

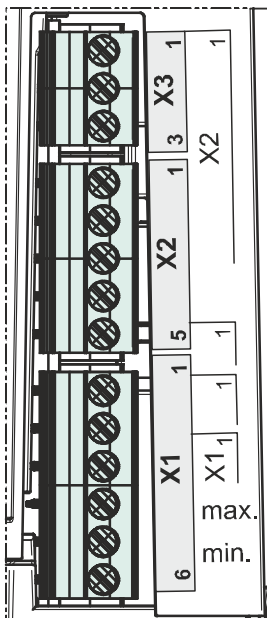
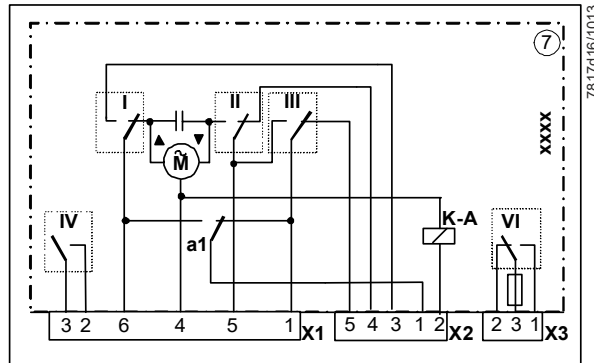

Mains voltage terminals			Dimensioning	
X3-1	Auxiliary switch AUX (VI) NO contact	Output	AC 120 V / AC 230 V / max. 1 A, $\cos\varphi > 0.9$ **	
X3-2	Auxiliary switch AUX (VI) NC opener	Output	AC 120 V / AC 230 V / max. 1 A, $\cos\varphi > 0.9$ **	
X3-3	Auxiliary switch AUX (VI)	Input	AC 120 V / AC 230 V / max. 1 A, $\cos\varphi > 0.9$ **	
X2-1	Mains voltage	Input	AC 120 V / AC 230 V / max. 1 A, $\cos\varphi > 0.9$	
X2-2	Open / close relay	Input	AC 120 V / AC 230 V / max. 1 A, $\cos\varphi > 0.9$	
X2-3	'OPEN' position reached (I)	Output	AC 120 V / AC 230 V / max. 0.3 A, $\cos\varphi > 0.8$	
X2-4	'CLOSED' position reached (II)	Output	AC 120 V / AC 230 V / max. 0.3 A, $\cos\varphi > 0.8$	
X2-5	Ignition position reached (III)	Output	AC 120 V / AC 230 V / max. 0.3 A, $\cos\varphi > 0.8$	
X1-1	Move to ignition position (III)	Input	AC 120 V / AC 230 V / max. 1 A, $\cos\varphi > 0.9$	
X1-2	Auxiliary switch AUX (IV) NO contact	Output	AC 120 V / AC 230 V / max. 1 A, $\cos\varphi > 0.9$	
X1-3	Auxiliary switch AUX (IV)	Input	AC 120 V / AC 230 V / max. 1 A, $\cos\varphi > 0.9$	
X1-4	Neutral	---	AC 120 V / AC 230 V / max. 1 A, $\cos\varphi > 0.9$	
X1-5	Closing (II)	Input	AC 120 V / AC 230 V / max. 1 A, $\cos\varphi > 0.9$	
X1-6	Opening (I)	Input	AC 120 V / AC 230 V / max. 1 A, $\cos\varphi > 0.9$	



### Please note!

\*\* When connecting a fuel valve: Max. 0.3 A,  $\cos\varphi > 0.8$  inductive.

**Circuit diagrams and connection terminals (continued)**

**SQM4x.x7xxxx**

2-position version with 2 end switches and 3 auxiliary switches, 1 relays



**Note!**  
The setting of the switch positions must be checked before commissioning.

- Cam VI: Auxiliary switch
- Cam V:
- Cam IV: Auxiliary switch
- Cam III: Ignition position
- Cam II: Closed
- Cam I: High-fire / open position

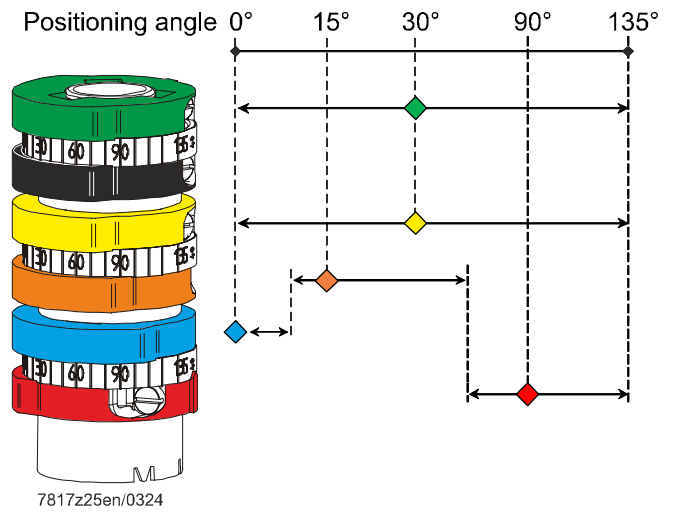

7817z25en/0324

◇ Factory setting for switch position

SQM4x.x8xxxx

3 position version with 2 end switches and 4 auxiliary switches



**Note!**  
For the sake of clarity, the plug-in contacts do not appear in sequential order in the circuit diagram. Consecutive numbers are printed on the unit, however, e.g. 1...7.

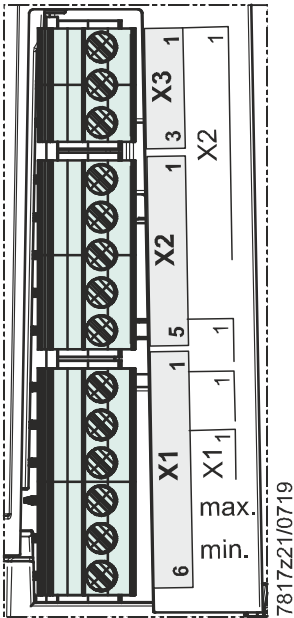
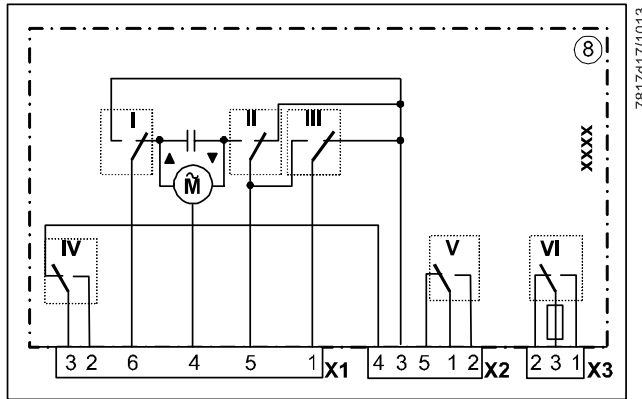

Mains voltage terminals		Dimensioning	
X3-1	Auxiliary switch AUX (VI) NO contact	Output	AC 120 V / AC 230 V / max. 1 A, $\cos\phi > 0.9$ **
X3-2	Auxiliary switch AUX (VI) NC opener	Output	AC 120 V / AC 230 V / max. 1 A, $\cos\phi > 0.9$ **
X3-3	Auxiliary switch AUX (VI)	Input	AC 120 V / AC 230 V / max. 1 A, $\cos\phi > 0.9$ **
X2-1	Auxiliary switch AUX (V)	Input	AC 120 V / AC 230 V / max. 1 A, $\cos\phi > 0.9$
X2-2	Auxiliary switch AUX (V) NO contact	Input	AC 120 V / AC 230 V / max. 1 A, $\cos\phi > 0.9$
X2-3	Position reached (I / II / III)	Output	AC 120 V / AC 230 V / max. 0.3 A, $\cos\phi > 0.8$
X2-4	Auxiliary switch AUX (IV) NC opener	Output	AC 120 V / AC 230 V / max. 1 A, $\cos\phi > 0.9$
X2-5	Auxiliary switch AUX (V) NC opener	Output	AC 120 V / AC 230 V / max. 1 A, $\cos\phi > 0.9$
X1-1	Move to position (III)	Input	AC 120 V / AC 230 V / max. 1 A, $\cos\phi > 0.9$
X1-2	Auxiliary switch AUX (IV) NO contact	Output	AC 120 V / AC 230 V / max. 1 A, $\cos\phi > 0.9$
X1-3	Auxiliary switch AUX (IV)	Input	AC 120 V / AC 230 V / max. 1 A, $\cos\phi > 0.9$
X1-4	Neutral	Input	AC 120 V / AC 230 V / max. 1 A, $\cos\phi > 0.9$ inductive
X1-5	Closing (II)	Input	AC 120 V / AC 230 V / max. 1 A, $\cos\phi > 0.9$
X1-6	Opening (I)	Input	AC 120 V / AC 230 V / max. 1 A, $\cos\phi > 0.9$



**Please note!**  
\*\* When connecting a fuel valve: Max. 0.3 A,  $\cos\phi > 0.8$  inductive.

Circuit diagrams and connection terminals (continued)

SQM4x.x8xxxx

3-position version with 2 end switches and 4 auxiliary switches



**Note!**  
The setting of the switch positions must be checked before commissioning.

- Cam VI: Auxiliary switch
- Cam V: Auxiliary switch
- Cam IV: Auxiliary switch
- Cam III: Ignition position
- Cam II: Closed
- Cam I: High-fire / open position

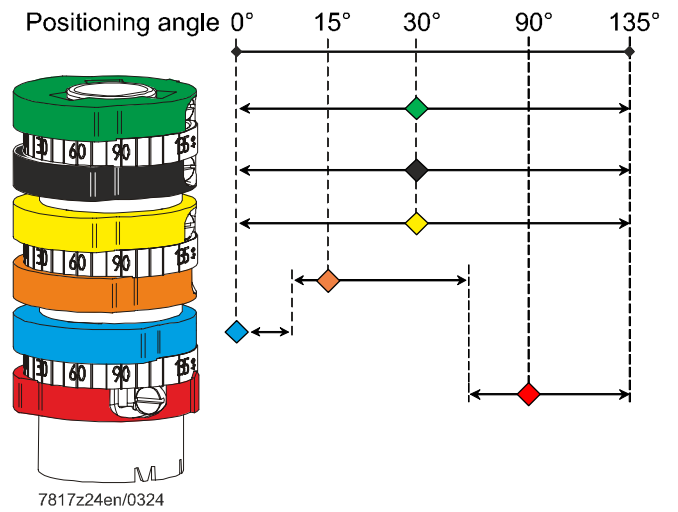

◇ Factory setting for switch position

# Dimensions

Dimensions in mm

## SQM40/SQM41

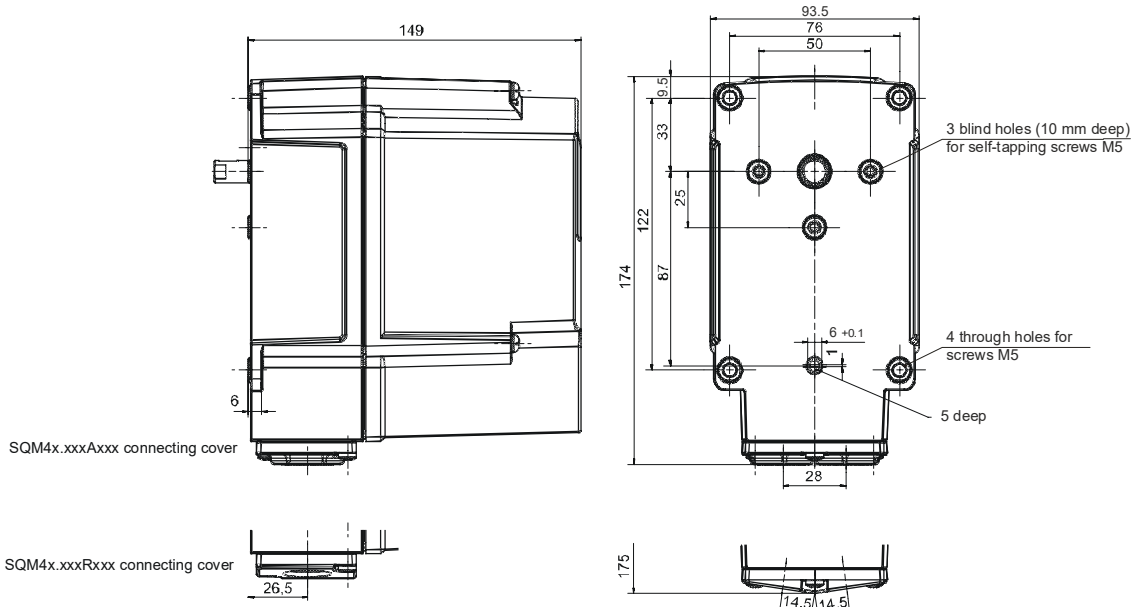

			Shaft no.
SQM4x.xx1xxx	Slot for woodruff key 3x3.7 series A Din6888		1
SQM4x.xx4xxx	Square		4
SQM4x.xx5xxx	D-shaft		5
SQM4x.xx7xxx	Slot for parallel key A5x3x28 DIN6885 T3		7

7817m01e/0216

## Accessories

---

Accessories must be ordered as separate items:



### Proportional controlling element with mounting plate

**VKPx**

Proportional controlling element for mounting between threaded flanges in gas trains. Refer to data sheet N7632.

---



### Butterfly valve

**VKF1x**

Butterfly valves designed in intermediate flange design, for mounting into gas trains. Refer to Data Sheet N7673.

---



### Mounting plate

**ASK33.1**

Article no.: **BPZ:ASK33.1**

For mounting the SQM40.xx5xxx on the VKP proportional controlling element or on the VKF1x butterfly valve.



#### Note!

The required screws (3x M5 countersunk screws and 4x M5 screws) are included in the packaging for the ASK33.1.

---



### Front cover (on request)

For making the connections for the power supply lines

- For 1/2" NPT protective sleeve

- For metric cable gland

**AGA45.1**

Article no.: **BPZ:AGA45.111**

**AGA45.12**

Article no.: **BPZ:AGA45.12**

---



#### Note!

Front covers AGA45.11 and AGA45.12 are only to be used as replacements.

The corresponding AGA45 version is factory-prefitted onto the SQM40 / SQM41

---

### Connector sets (on request)

With screw terminals for replacement:

- For SQM4x.x1xxxx

- For SQM4x.x2xxxx, SQM4x.x5xxxx

- For SQM4x.x3xxxx, SQM4x.x6xxxx, SQM4x.x7xxxx, SQM4x.x8xxxx

**AGA45.1**

Article no.: **BPZ:AGA45.1**

**AGA45.5**

Article no.: **BPZ:AGA45.5**

**AGA45.6**

Article no.: **BPZ:AGA45.6**

---



## Accessories (cont'd)

---

Accessories must be ordered as separate items:

### Potentiometers

For retrofitting



- For SQM40 / SQM41: Double potentiometer 2\*1000  $\Omega$ , 90°

**ASZ22.32**

Article no.: **S55852-Z301-A100**

- For SQM40: Double potentiometer 2\*1000  $\Omega$ , 135°

**ASZ22.35**

Article no.: **S55852-Z303-A100**

- For SQM41: Double potentiometer 2\*1000  $\Omega$ , 135°

**ASZ22.34**

Article no.: **S55852-Z302-A100**

Refer to Data Sheet N7921.



#### Note!

ASZ22.3x potentiometers are only intended for the retrofitting onto SQM40 / SQM41 types with the end number 0 (SQM4x.xxxx0).

For all SQM40/SQM41 types with the end number 1 (SQM4x.xxxx1) or 3 (SQM4x.xxxx3), the potentiometers are factory installed.

## Mounting the SQM40.xx5xxx onto the VKP proportional controlling element

### Step 1:

- Loosen the screws (M5)
- Remove the plate in the direction of the arrow

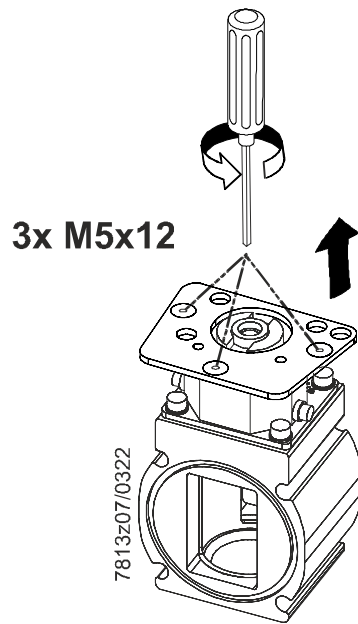

### Step 2:

- Loosen the screws (1)
- Pull the plate in the direction of the arrow (2) and remove the reducing sleeve (3)

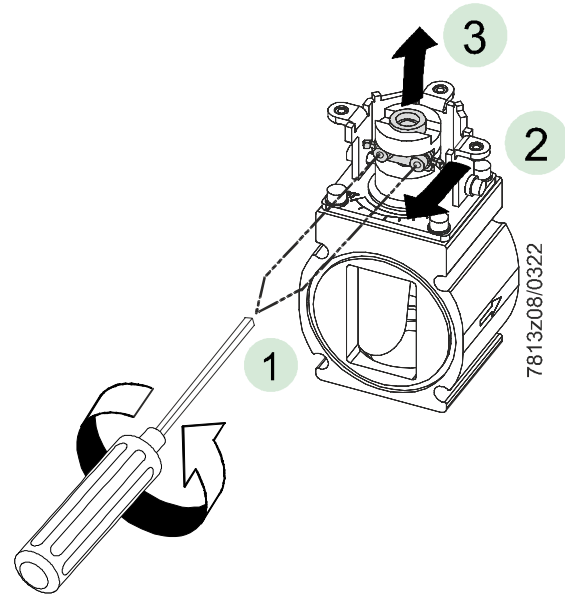

### Step 3:

- Place the ASK33.1 mounting plate in the direction of the arrow
- Tighten the screws (M5)

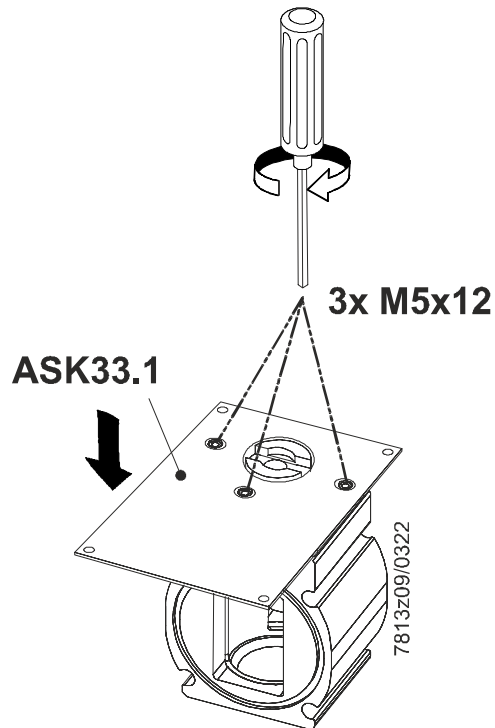

### Step 4:

- Loosen the screws (1)
- Remove the housing cover in the direction of the arrow (2)

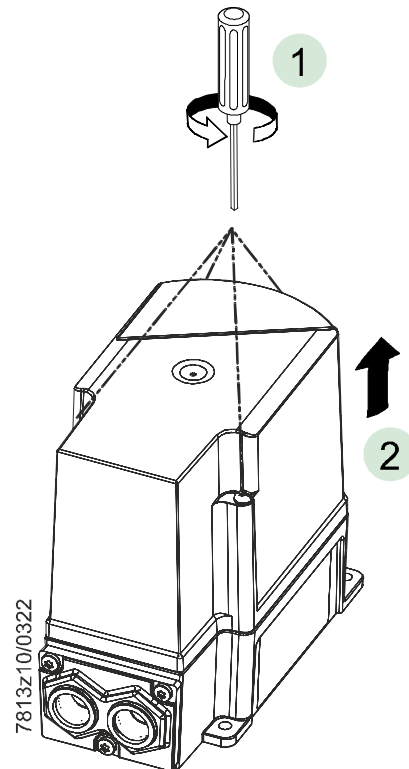



## Mounting the SQM40.xx5xxx onto the VKP proportional controlling element (continued)

### Step 5:

Check the zero position

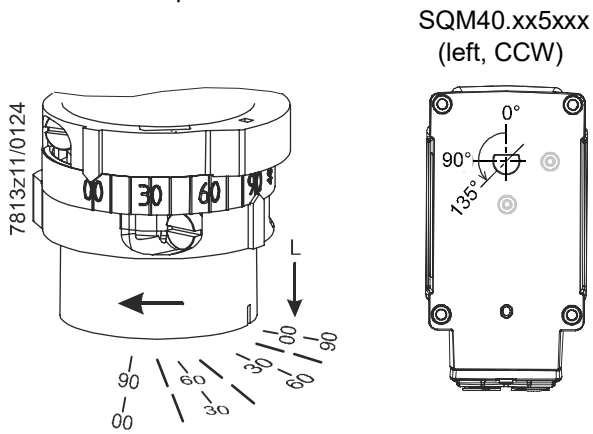

### Step 6:

- Loosen the screws (1)
- Pull the plate in the direction of the arrow (2) and mount the SQM40.xx5xxx

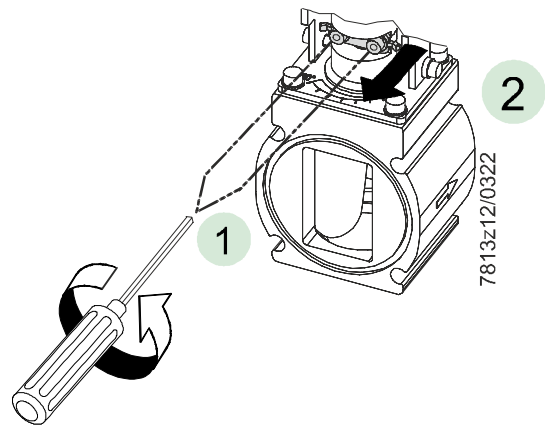

### Step 7:

Position the SQM40.xx5xxx

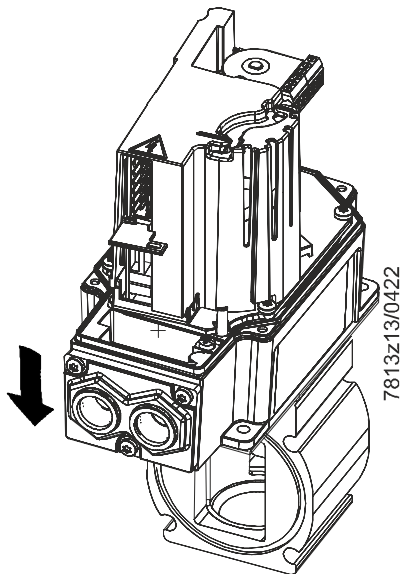

### Step 8:

Tighten the screws

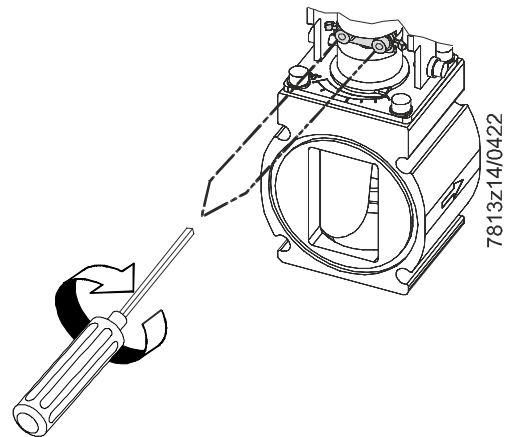

## Mounting the SQM40.xx5xxx onto the VKP proportional controlling element (continued)

### Step 9:

Screw the SQM40.xx5xxx to the plate

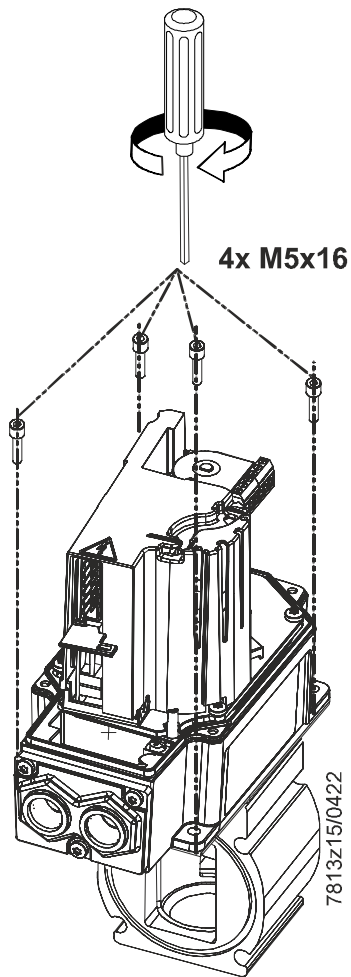

### Step 10:

- Fit the housing cover in the direction of the arrow (2)
- Tighten the screws (1)

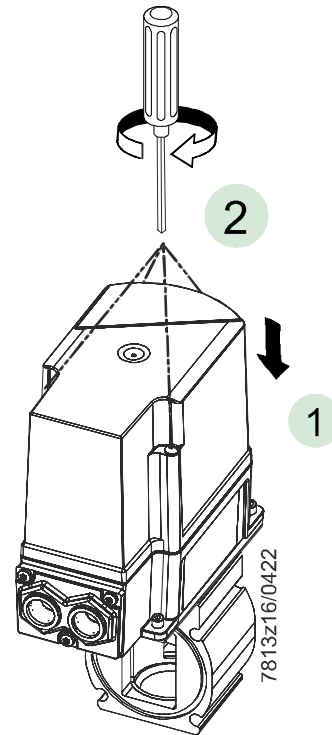

## Mounting the SQM40.xx5xxx onto the VKF1x butterfly valve

### VKF10 / VKF11

VKF10/VKF11 contents

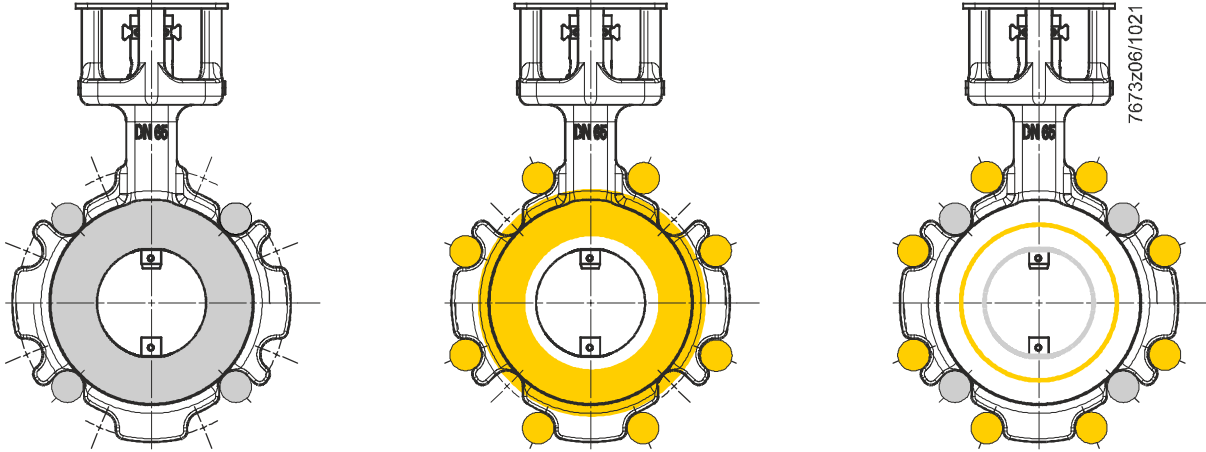
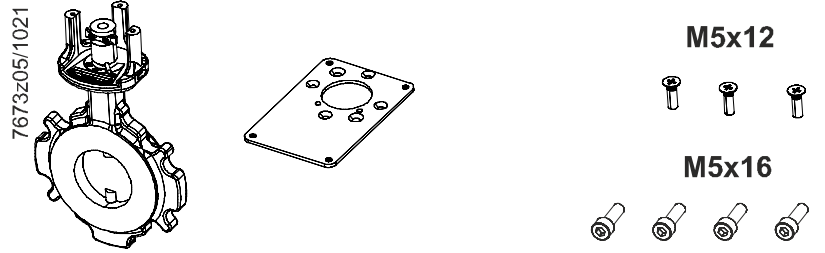

Nominal size DN	Swing thru	With mechanical stop	Suitable for flange size	Tightening torque	Mounting			
					DN ISO	DN ASME	DN+1 ISO	DN+1 ASME
32	VKF10.032	VKF11.032	DN32 + DN40	50 Nm	4 x M16	4 x 1/2	4 x M16	4 x 1/2
40	VKF10.040	VKF11.040	DN40 + DN50	50 Nm	4 x M16	4 x 1/2	4 x M16	4 x 5/8
50	VKF10.050	VKF11.050	DN50 + DN65	50 Nm	4 x M16	4 x 5/8	4 x M16	4 x 5/8
65	VKF10.065	VKF11.065	DN65 + DN80	50 Nm	4 x M16	4 x 5/8	8 x M16	4 x 5/8
80	VKF10.080	VKF11.080	DN80 + DN100	50 Nm	8 x M16	4 x 5/8	8 x M16	4 x 5/8
100	VKF10.100	VKF11.100	DN100 + DN125	80 Nm	8 x M16	8 x 5/8	8 x M16	8 x 3/4
125	VKF10.125	VKF11.125	DN125 + DN150	160 Nm	8 x M16	8 x 3/4	8 x M20	8 x 3/4
150	VKF10.150	VKF11.150	DN150 + DN200	160 Nm	8 x M20	8 x 3/4	12 x M20	8 x 3/4
200	VKF10.200	VKF11.200	DN200	160 Nm	12 x M20	8 x 3/4	---	---

Mounting position of the mounting plate

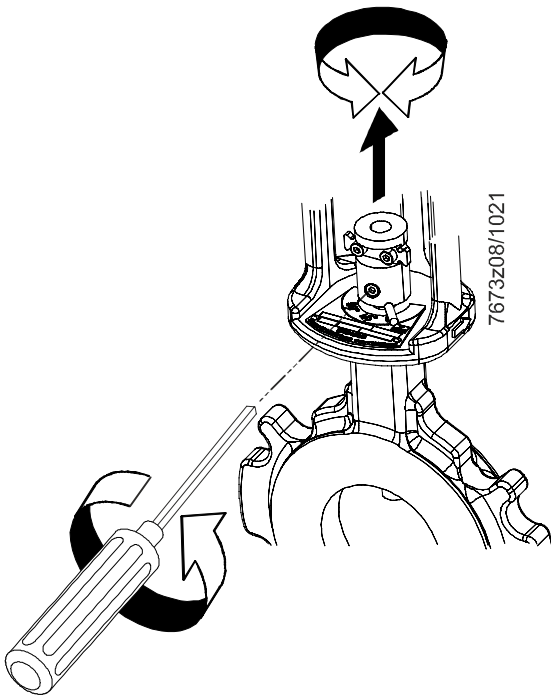
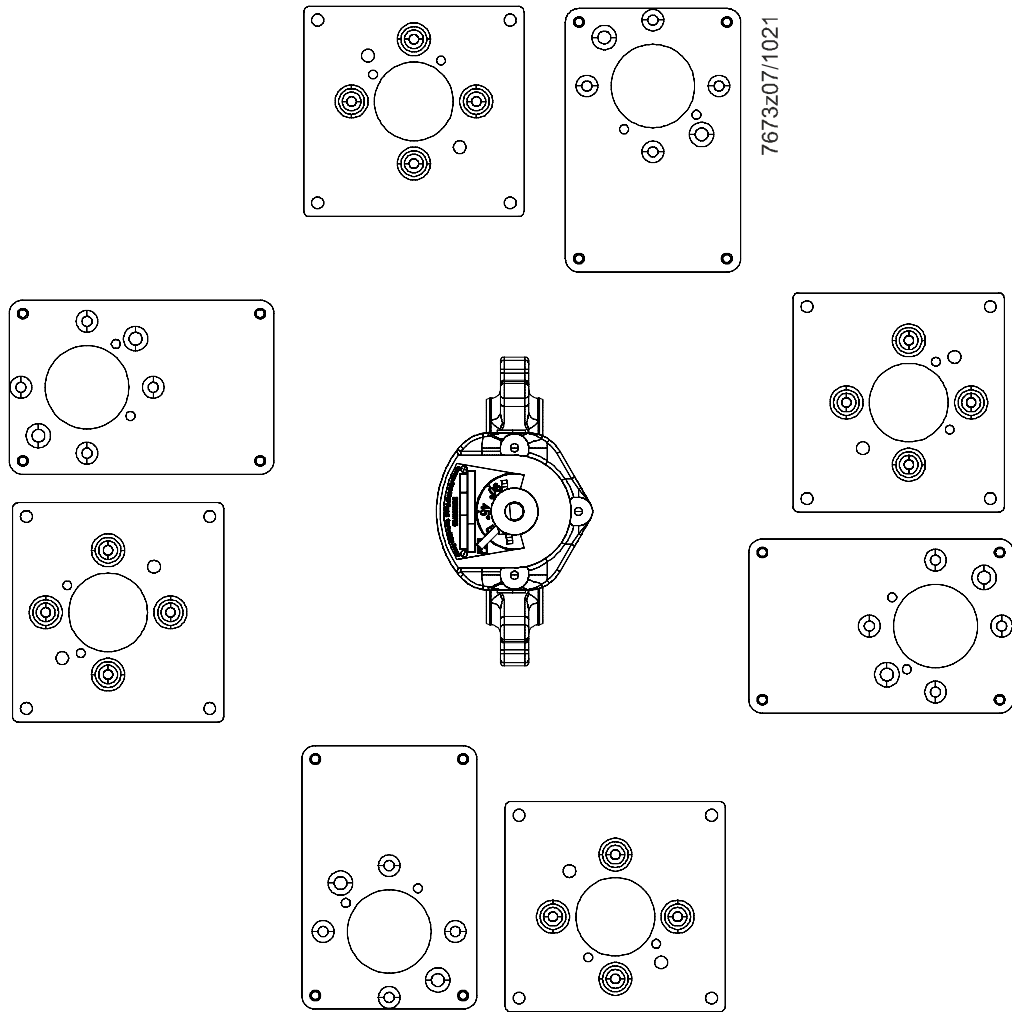

**Step 1:**

Loosen the screw. Align the coupling to suit the mounting position of the mounting plate. Tighten the screw again (max. 2 Nm).

**Mounting the SQM40.xx5xxx onto the VKF1x butterfly valve (continued)**

**Step 2:**

- Place the ASK33.1 mounting plate in the direction of the arrow
- Tighten the screws (M5)

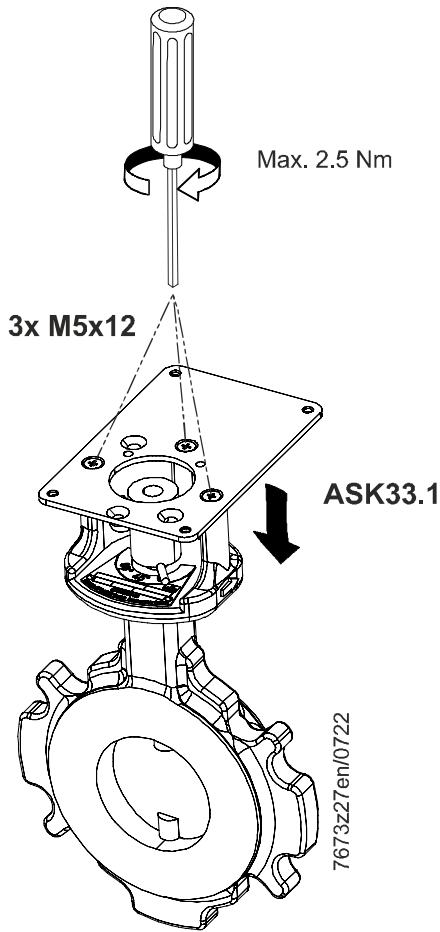

**Step 3:**

- Loosen the screws (1)
- Remove the housing cover in the direction of the arrow (2)

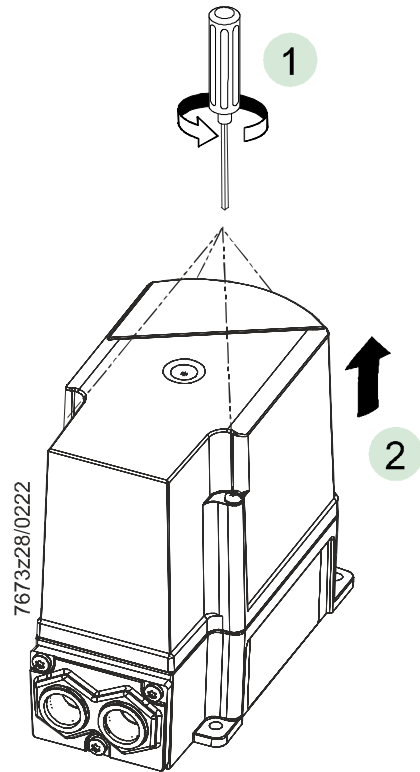

**Step 4:**

Press the pressure pin down to release the coupling.

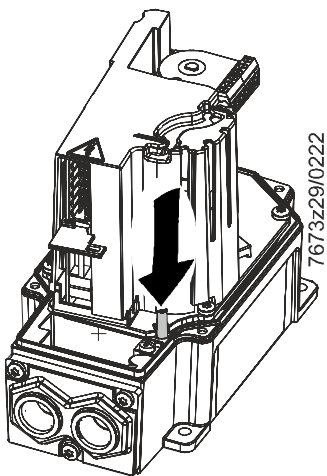

**Step 5:**

Then move the pressure pin towards the flattened side to fix the pressure pin in this position.

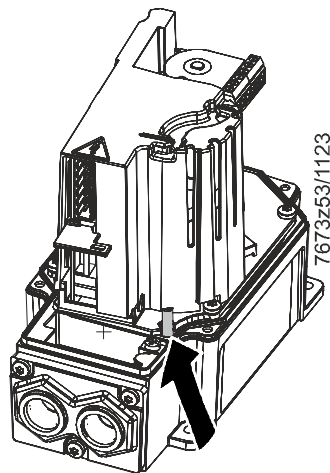

**Step 6:**

Check the zero position.

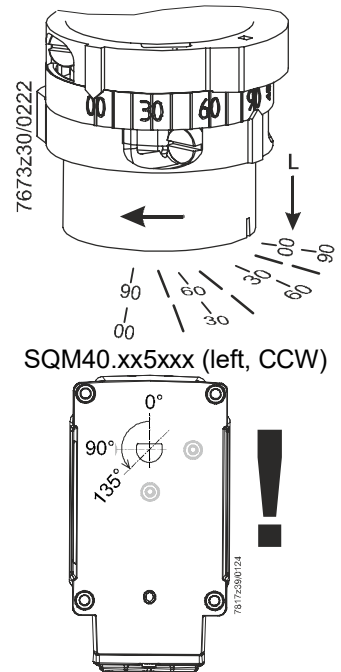

## Mounting the SQM40.xx5xxx onto the VKF1x butterfly valve (continued)

### Step 7:

- Loosen the screws (1)
- Pull the plate in the direction of the arrow (2) so that the D-shaft of the SQM40.xx5xxx can be pushed into the coupling. Then fit the SQM40.xx5xxx

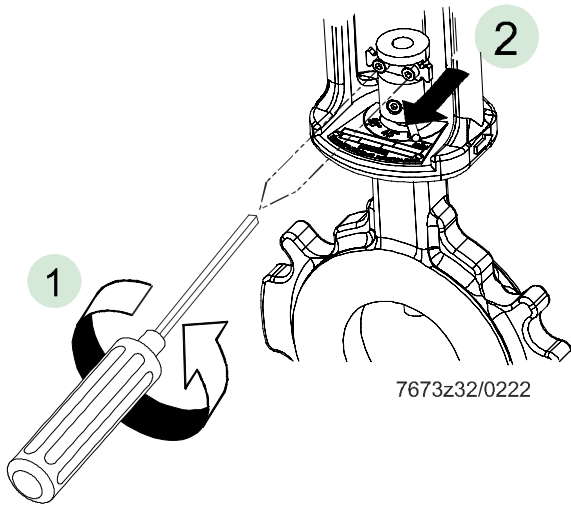

### Step 8:

- Position the SQM40.xx5xxx in the direction of the arrow (1)
- Screw the SQM40.xx5xxx onto the plate (2)

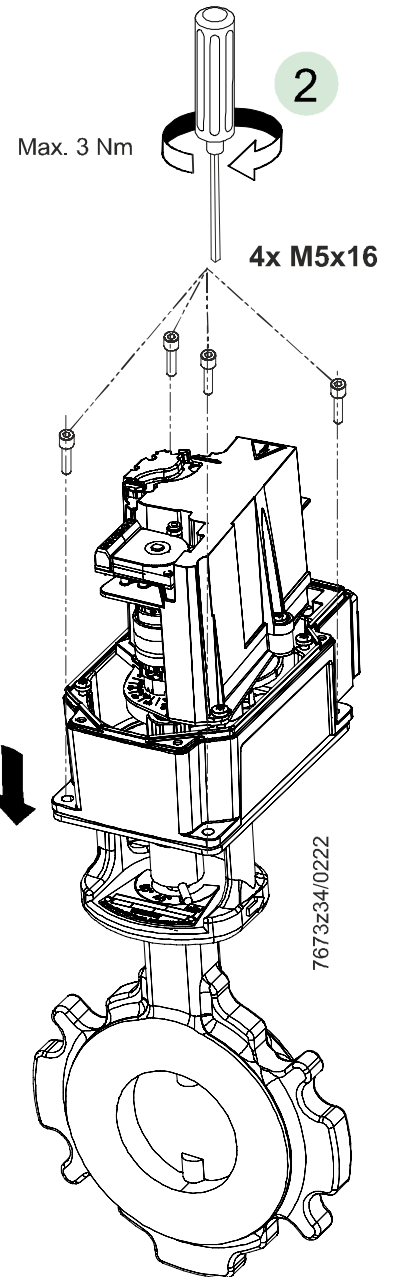

### Step 9:

Lock the coupling while loosening the pressure pin.

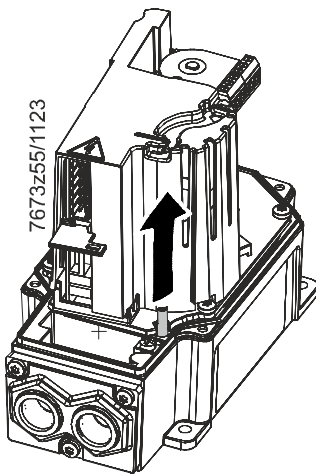

### Step 10:

Move the pressure pin away from the flattened side to release the pressure pin from the lock and thus fix the coupling.

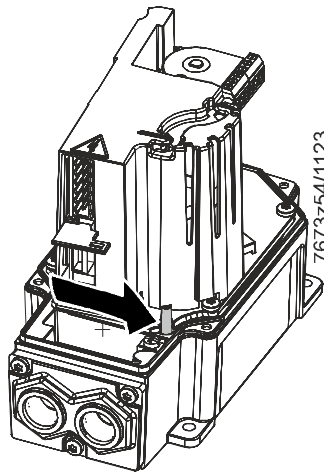

## Mounting the SQM40.xx5xxx onto the VKF1x butterfly valve (continued)

### Step 11:

- Fit the housing cover in the direction of the arrow
- Tighten the screws

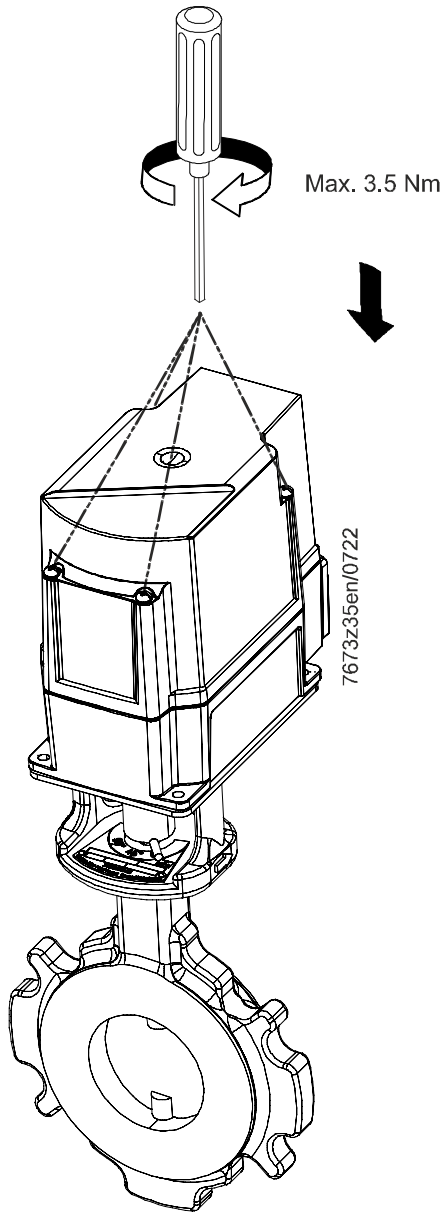

### Step 12:

Tighten the screws (max. 2 Nm).

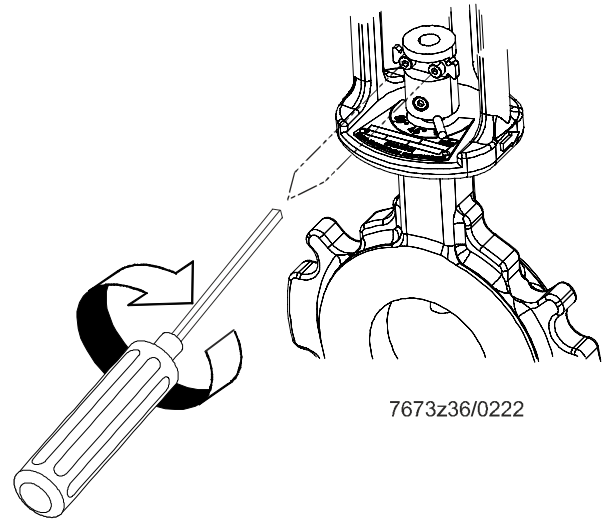

# Installation of the ASZ22.3x

## Double potentiometer → SQM40/SQM41

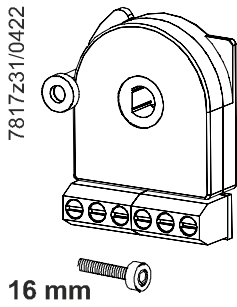

ASZ22.32 → SQM40 / SQM41	2x 1000 Ω, 90°
ASZ22.34 → SQM41	2x 1000 Ω, 135°
ASZ22.35 → SQM40	2x 1000 Ω, 135°

**Step 1:**  
Select potentiometer.

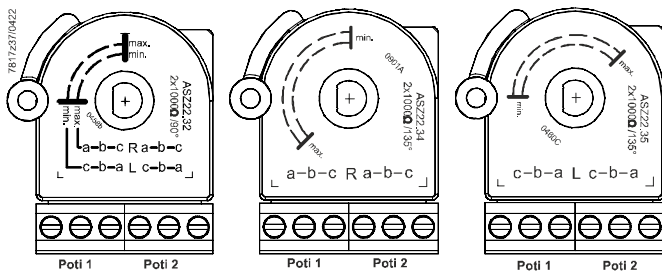

**Step 2:**

- Loosen the screws (1)
- Remove the housing cover in the direction of the arrow (2)

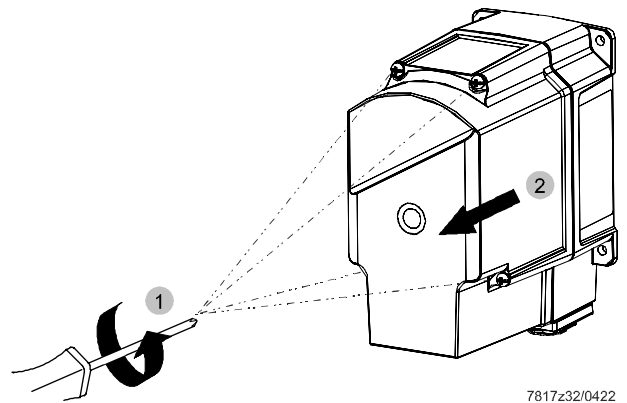

**Step 3:**

- Disengage (1)
- Turn the shaft (2) until the flattened side at the mounting point for the potentiometer (3) points downwards

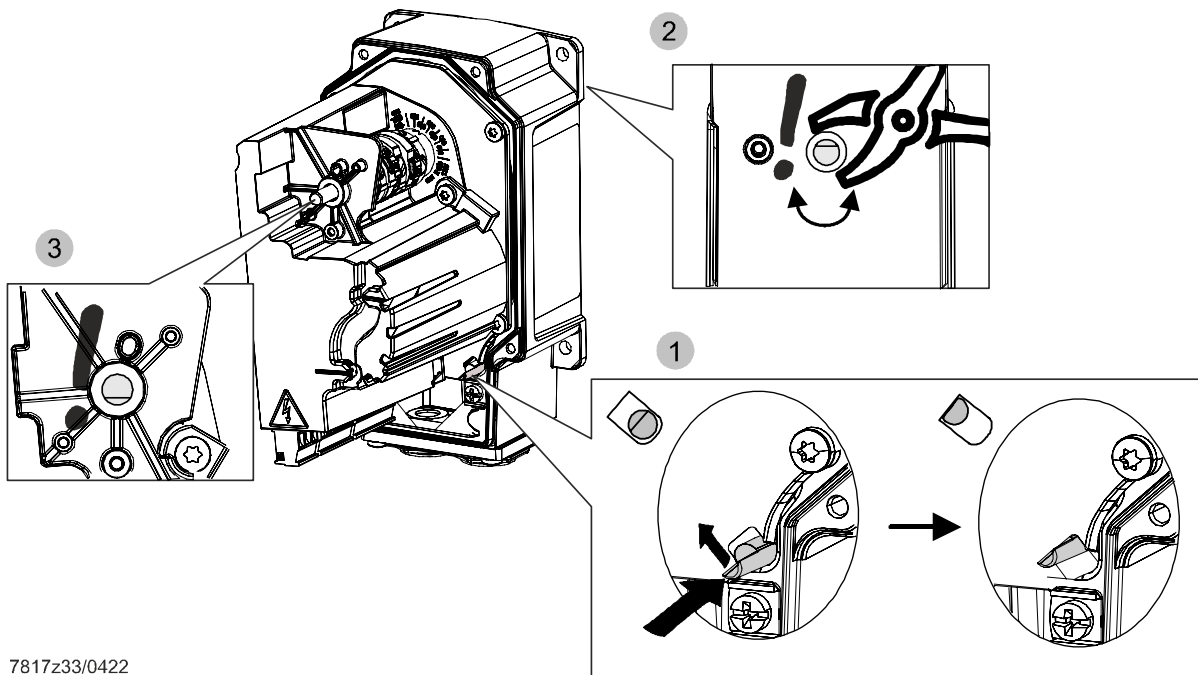



**Step 4:**  
Engage

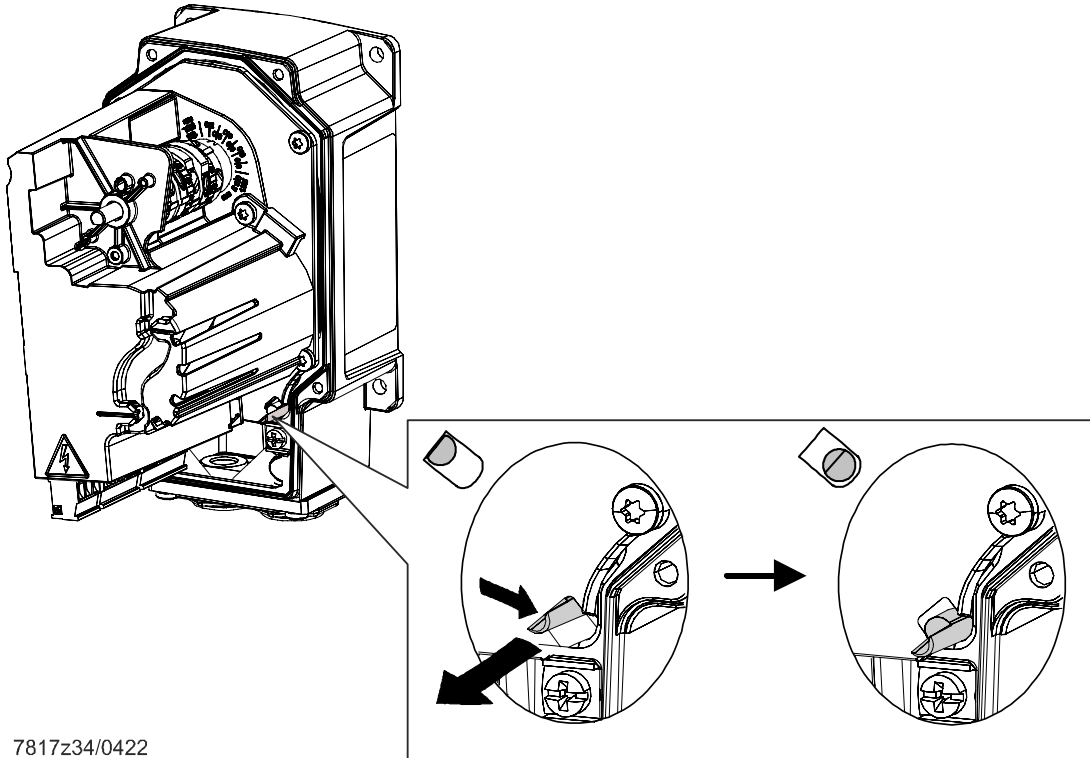

**Step 5:**  
Push the potentiometer onto the shaft as far as it will go.

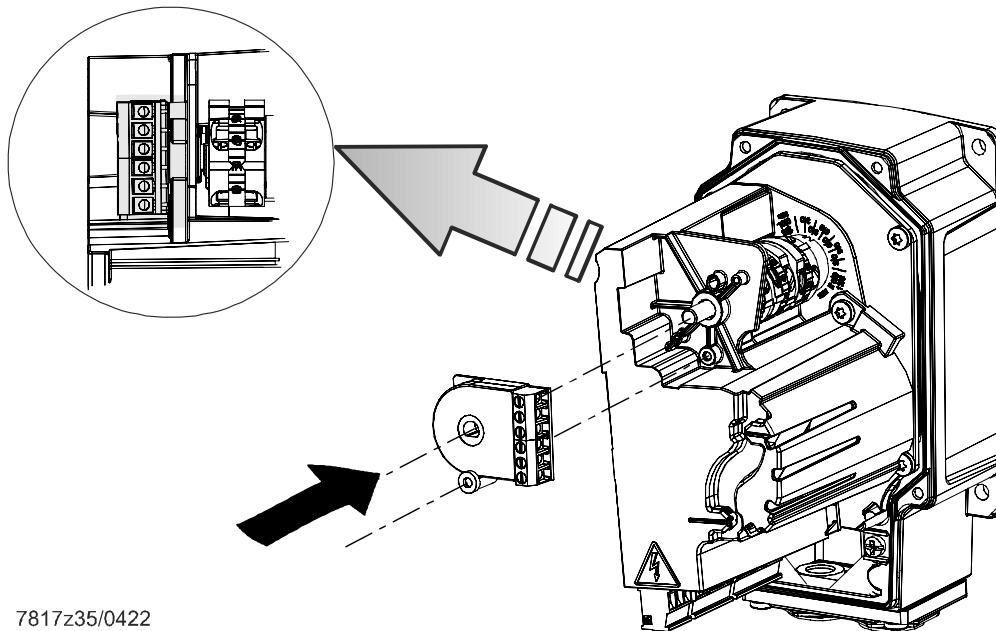

## Installation of the ASZ22.3x (continued)

### Step 6:

Tighten the screws (max. 0.8 Nm).

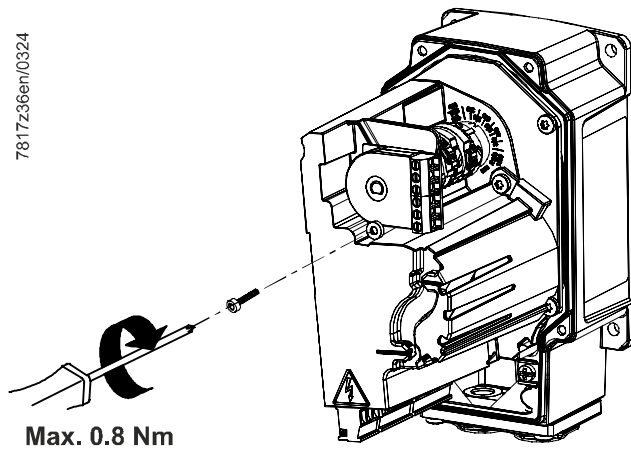

### Step 7:

- Fit the housing cover in the direction of the arrow (1)
- Tighten the screws (2) (maximum 3.5 Nm)

